



Video Wall Controller

User Manual

Legal Information

About this Document

- This Document includes instructions for using and managing the Product. Pictures, charts, images and all other information hereinafter are for description and explanation only.
- The information contained in the Document is subject to change, without notice, due to firmware updates or other reasons. Please find the latest version of the Document at the Hikvision website (<https://www.hikvision.com>). Unless otherwise agreed, Hangzhou Hikvision Digital Technology Co., Ltd. or its affiliates (hereinafter referred to as "Hikvision") makes no warranties, express or implied.
- Please use the Document with the guidance and assistance of professionals trained in supporting the Product.

About this Product

This product can only enjoy the after-sales service support in the country or region where the purchase is made.

Acknowledgment of Intellectual Property Rights

- Hikvision owns the copyrights and/or patents related to the technology embodied in the Products described in this Document, which may include licenses obtained from third parties.
- Any part of the Document, including text, pictures, graphics, etc., belongs to Hikvision. No part of this Document may be excerpted, copied, translated, or modified in whole or in part by any means without written permission.
- **HIKVISION** and other Hikvision's trademarks and logos are the properties of Hikvision in various jurisdictions.
- Other trademarks and logos mentioned are the properties of their respective owners.
- **HDMI**[™] The terms HDMI and HDMI High-Definition Multimedia Interface, and the HDMI Logo are trademarks or registered trademarks of HDMI Licensing Administrator, Inc. in the United States and other countries.

LEGAL DISCLAIMER

- TO THE MAXIMUM EXTENT PERMITTED BY APPLICABLE LAW, THIS DOCUMENT AND THE PRODUCT DESCRIBED, WITH ITS HARDWARE, SOFTWARE AND FIRMWARE, ARE PROVIDED "AS IS" AND "WITH ALL FAULTS AND ERRORS". HIKVISION MAKES NO WARRANTIES, EXPRESS OR IMPLIED, INCLUDING WITHOUT LIMITATION, MERCHANTABILITY, SATISFACTORY QUALITY, OR FITNESS FOR A PARTICULAR PURPOSE. THE USE OF THE PRODUCT BY YOU IS AT YOUR OWN RISK. IN NO EVENT WILL HIKVISION BE LIABLE TO YOU FOR ANY SPECIAL, CONSEQUENTIAL, INCIDENTAL, OR INDIRECT DAMAGES, INCLUDING, AMONG OTHERS, DAMAGES FOR LOSS OF BUSINESS PROFITS, BUSINESS INTERRUPTION, OR LOSS OF DATA, CORRUPTION OF SYSTEMS, OR LOSS OF DOCUMENTATION, WHETHER BASED ON BREACH OF CONTRACT, TORT (INCLUDING NEGLIGENCE), PRODUCT LIABILITY, OR OTHERWISE, IN CONNECTION WITH THE USE OF THE PRODUCT, EVEN IF HIKVISION HAS BEEN ADVISED OF THE POSSIBILITY OF SUCH DAMAGES OR LOSS.
- YOU ACKNOWLEDGE THAT THE NATURE OF THE INTERNET PROVIDES FOR INHERENT SECURITY RISKS, AND

HIKVISION SHALL NOT TAKE ANY RESPONSIBILITIES FOR ABNORMAL OPERATION, PRIVACY LEAKAGE OR OTHER DAMAGES RESULTING FROM CYBER-ATTACK, HACKER ATTACK, VIRUS INFECTION, OR OTHER INTERNET SECURITY RISKS; HOWEVER, HIKVISION WILL PROVIDE TIMELY TECHNICAL SUPPORT IF REQUIRED.

- YOU AGREE TO USE THIS PRODUCT IN COMPLIANCE WITH ALL APPLICABLE LAWS, AND YOU ARE SOLELY RESPONSIBLE FOR ENSURING THAT YOUR USE CONFORMS TO THE APPLICABLE LAW. ESPECIALLY, YOU ARE RESPONSIBLE, FOR USING THIS PRODUCT IN A MANNER THAT DOES NOT INFRINGE ON THE RIGHTS OF THIRD PARTIES, INCLUDING WITHOUT LIMITATION, RIGHTS OF PUBLICITY, INTELLECTUAL PROPERTY RIGHTS, OR DATA PROTECTION AND OTHER PRIVACY RIGHTS. YOU SHALL NOT USE THIS PRODUCT FOR ANY PROHIBITED END-USES, INCLUDING THE DEVELOPMENT OR PRODUCTION OF WEAPONS OF MASS DESTRUCTION, THE DEVELOPMENT OR PRODUCTION OF CHEMICAL OR BIOLOGICAL WEAPONS, ANY ACTIVITIES IN THE CONTEXT RELATED TO ANY NUCLEAR EXPLOSIVE OR UNSAFE NUCLEAR FUEL-CYCLE, OR IN SUPPORT OF HUMAN RIGHTS ABUSES.
- IN THE EVENT OF ANY CONFLICTS BETWEEN THIS DOCUMENT AND THE APPLICABLE LAW, THE LATTER PREVAILS.

© Hangzhou Hikvision Digital Technology Co., Ltd. All rights reserved.

Preface

Applicable Models

This manual is applicable to the DS-C60S series video wall controller.

Default Parameters



Type	Default Parameter
Device	• Login user name: admin
SSH connection	• IP address: 192.0.0.64

Caution

To improve system security, it is highly recommended to change password regularly. In order to protect your privacy and corporate data and avoid network security issues, it is recommended to set strong password that meets security requirements.

Symbol Conventions

The symbols that may be found in this document are defined as follows.

Symbol	Description
 Note	Provides additional information to emphasize or supplement important points of the main text.
 Caution	Indicates a potentially hazardous situation, which if not avoided, could result in equipment damage, data loss, performance degradation, or unexpected results.
 Danger	Indicates a hazard with a high level of risk, which if not avoided, will result in death or serious injury.

Safety Instructions

Caution

In the use of the product, you must be in strict compliance with the electrical safety regulations of the nation and region.

Note

- Provide a surge suppressor at the inlet opening of the device under special conditions such as the mountain top, iron tower, and forest.
- + identifies the positive terminals of the device which is used with, or generates direct current, and - identifies the negative terminals of the device which is used with, or generates direct current.
- The serial port of the device is used for debugging only.
- The interface varies with the models. Please refer to the product datasheet for details.

TABLE OF CONTENTS

Chapter 1 Introduction	1
1.1 Overview	1
1.2 First-Time Configuration Process	2
Chapter 2 Device Basic Settings	3
2.1 Connect Screen and Device	3
2.2 Activate and Log In to Device	6
2.3 Configure the Network Address	9
Chapter 3 Video Wall Management	10
3.1 Configure Directly Connected LED Screens	10
3.1.1 Lighten the LED Screens	10
3.1.2 Configure LED Controller Board	15
3.1.3 Configure Multi-Function Card	22
3.2 Configure a Video Wall	25
3.2.1 Configure the Video Wall Scale	25
3.2.2 Configure the Output of a Video Wall	29
3.2.3 Manage Signal Sources	33
3.2.4 Bind Signal Sources with a Video Wall	35
3.3 Operate a Video Wall	38
3.3.1 Edit Signal Source Window Parameters	38
3.3.2 Configure Subtitles	41
3.3.3 Manage Scenes	43
3.3.4 Manage Plans	43
3.3.5 Maintain Screens	44
3.4 Configure Image Effect on Screen	49
3.4.1 Edit a Signal Source	49
3.4.2 Splice Signal Source	52
3.4.3 Set Other Parameters of Device	53
Chapter 4 Device Maintenance	56
4.1 View Device Status	56
4.2 Configure System Parameters	56
4.3 Configure HTTP(S) Parameters	59
4.4 Configure Events	60
4.5 Maintain the System	61
4.6 Maintain the Device Security	63

Chapter 1 Introduction

1.1 Overview

The video wall controller (hereinafter referred as the device) is the core control device of the screen splicing control system. As a new-generation FPGA-based pure hardware image processing device, it adopts the structure of main control board and service boards to provide the following advantages:

- Supports the video input and video output via various ports.
- Supports the network encoding and real-time preview of signal sources.
- Supports the decoding and output of various network signal sources.
- Supports the high-definition (HD) video splicing and fusion.
- Supports the window splicing, roaming window, and other operations.
- Supports the management on users, network, operation, alarm and logs.

1.2 First-Time Configuration Process

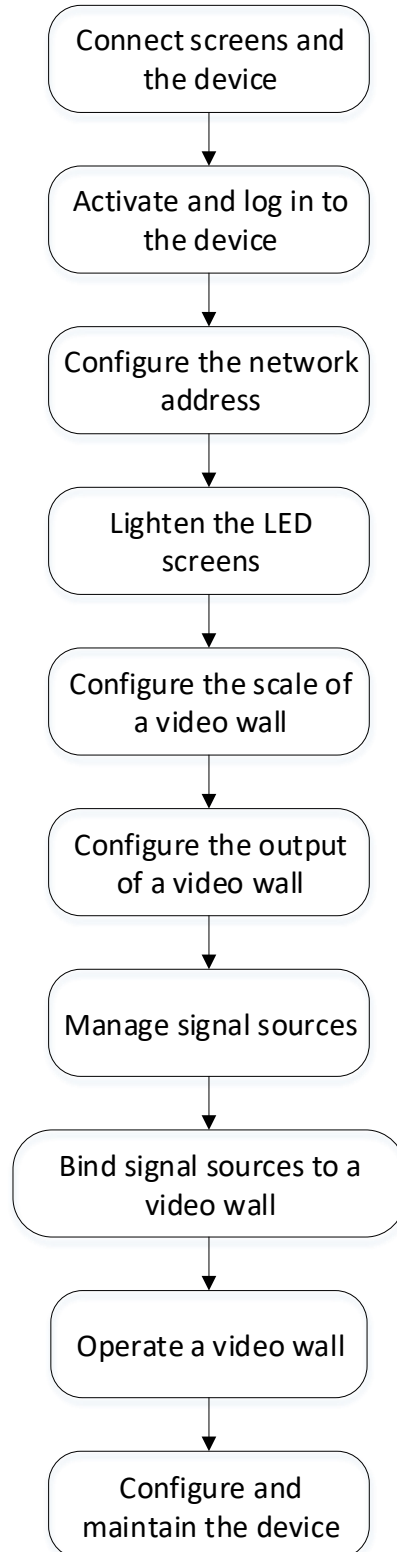

Figure 1-1 First-Time Configuration Process

Chapter 2 Device Basic Settings

2.1 Connect Screen and Device

Connect Single Device and Screens

- Connect an LCD screen and the device: Use a video cable to connect an output port of the device output board to an LCD screen.
- One LED screen consists of multiple LED cabinets. Take either of the following methods to connect an LED screen and the device:
 - Use multiple network cables to connect an external LED controller to multiple LED cabinets, and then use a video cable to connect an output port of the device output board to the external LED controller.
 - Use multiple network cables to connect an electrical LED controller board to multiple LED cabinets.



Note

The figure below is for illustration only.

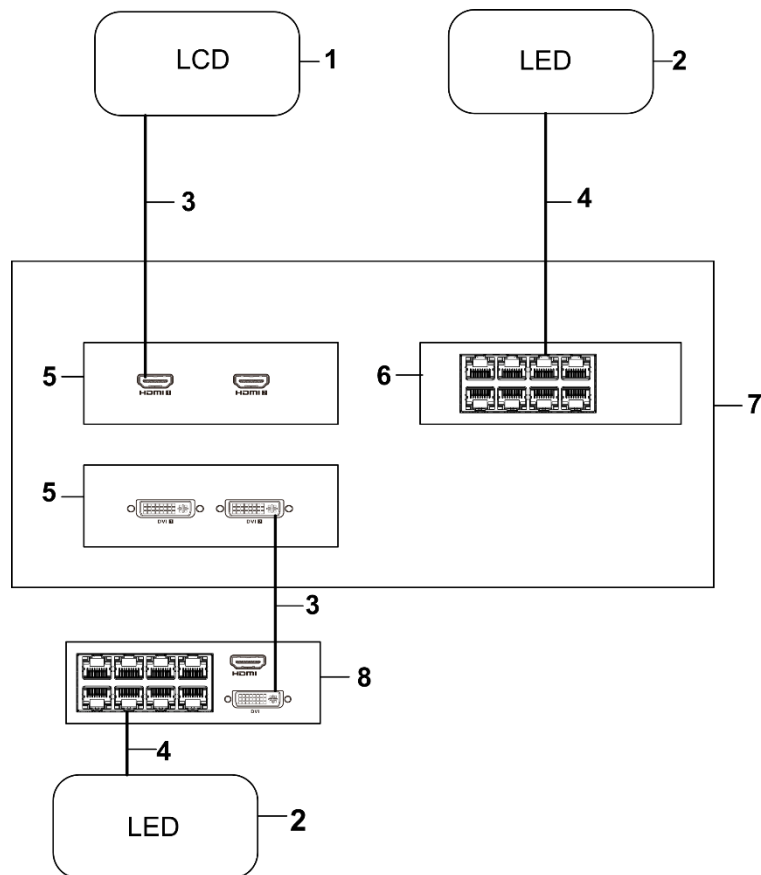

Figure 2-1 Connect Screen and Device

1. LCD screen	2. LED screen	3. HDMI or DVI video cable
4. Network cable	5. Output board	6. Electrical LED controller board
7. Device	8. External LED controller	

Connect Two Devices and Screens

Step 1 Connect the indoor device and outdoor device for long distance transmission.

- 1) Use multiple network cables to connect multiple electrical ports of an optical LED controller board in the outdoor device to multiple LED cabinets.
- 2) Use the optical fibers to connect the optical ports of the optical LED controller board in the outdoor device to the optical ports of the optical LED controller board in the indoor device.

Step 2 Connect the indoor device and a screen.

- Connect an LCD screen and the device: Use a video cable to connect an output port of the device output board to an LCD screen.
- Use multiple network cables to connect an external LED controller to multiple LED cabinets, and then use a video cable to connect an output port of the device output board to the external LED controller.



Note

The figure below is for illustration only.

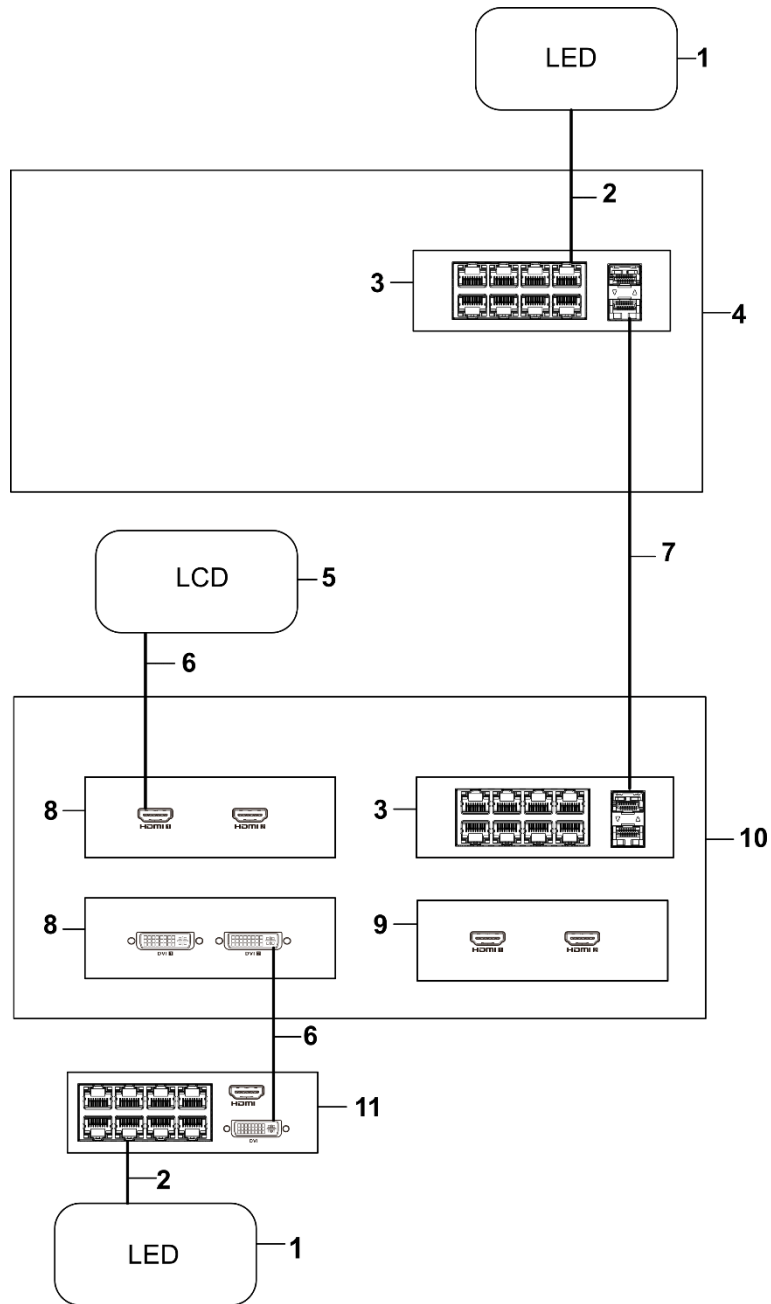

Figure 2-2 Connection for Long Distance Transmission

1. LED screen	2. Network cable	3. Optical LED controller board
4. Outdoor device	5. LCD screen	6. HDMI or DVI video cable
7. Optical fiber	8. Output board	9. Input board
10. Indoor device	11. External LED controller	

2.2 Activate and Log In to Device

You should activate the device before using the device for the first time. You can use the SADP client or the device web page to activate the device. When activating the device, obey the following requirements to set the password:

- To improve system security, it is highly recommended to change password regularly. In order to protect your privacy and corporate data, and avoid network security issues, it is recommended to set strong password that meets security requirements.
- Password should contain 8 to 16 characters and at least 2 of the following types: digits, lowercase letters, uppercase letters, and special characters.
- Password cannot contain user name, 123, admin (case insensitive), 4 or more continuously ascending or descending digits, or 4 or more consecutive repeated characters.

Use SADP Client and Web Page

Step 1 Connect the device and computer to the same LAN. Make sure the device and computer in the same network segment.

Step 2 Download and install the [SADP client](#) on the computer.

Step 3 Open the SADP client.

Step 4 Select the device that is not activated, enter the activation password and confirm it, and click **Activate**.

If the device cannot be found, you can restart the SADP client.

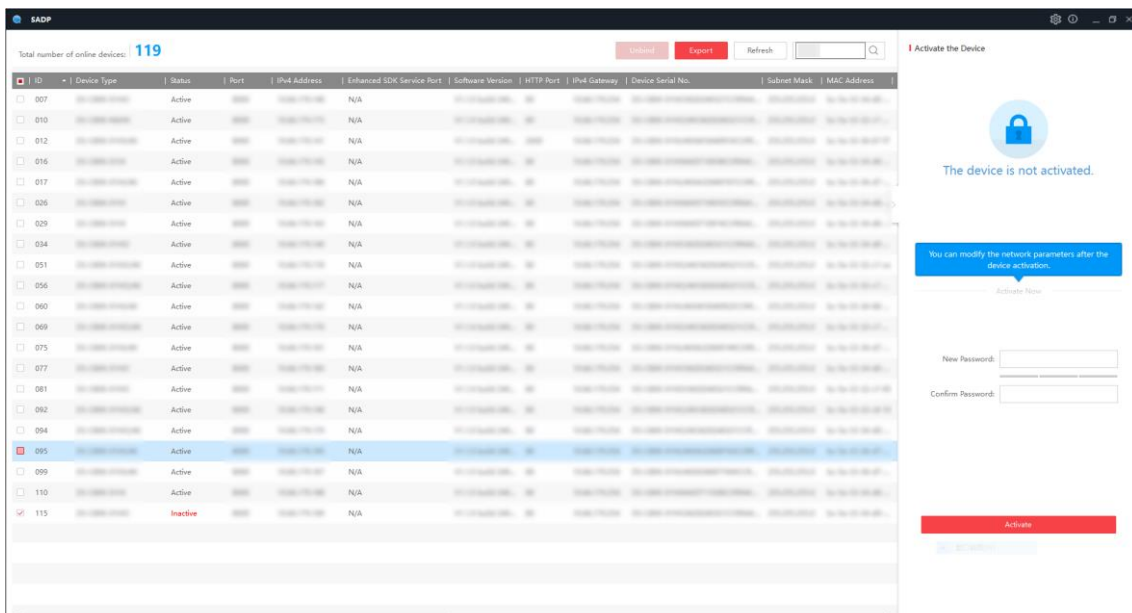

Figure 2-3 Activate the Device via SADP Client

Step 5 View the device IP address in the SADP client and enter the device IP address in the computer browser.

Step 6 Enter the user name and the set activation password, and then click **Log In**.

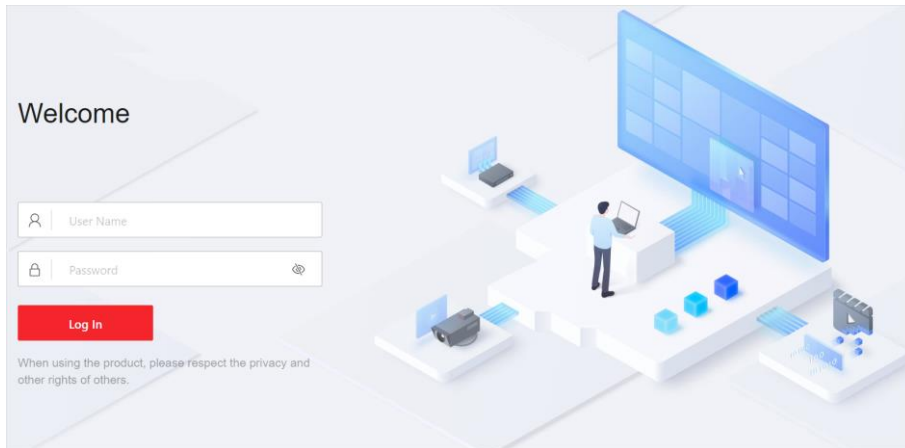

Figure 2-4 Login Page

Step 7 (Optional) To edit the password, you can click the username in the upper right corner of the web page and then click **Change Password**.

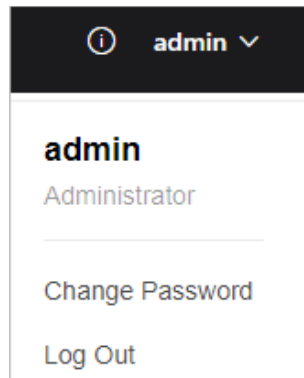

Figure 2-5 Change Password

Use Web Page

Step 1 Use a network cable to connect a computer to the device.

Step 2 Set the computer IP address to any IP address in the range of 192.0.0.2 to 192.0.0.253 (excluding 192.0.0.64) and set the computer gateway address to 192.0.0.1.

By default, the device IP address is 192.0.0.64 and the gateway address is 192.0.0.1.

Step 3 Enter 192.0.0.64 in the computer browser to enter the device activation page.

Step 4 Set the activation password, and then click **Activate**.

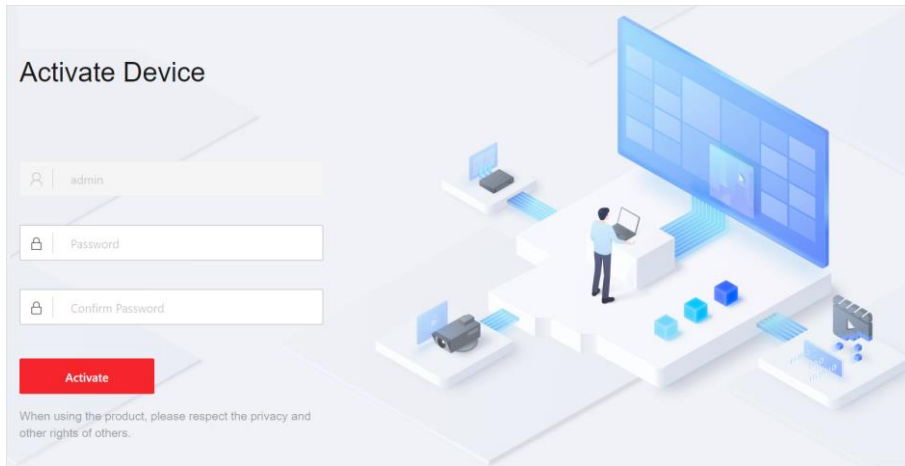

Figure 2-6 Activate the Device via Browser

Step 5 Enter the user name and the set activation password on the login page, and then click **Log In**.

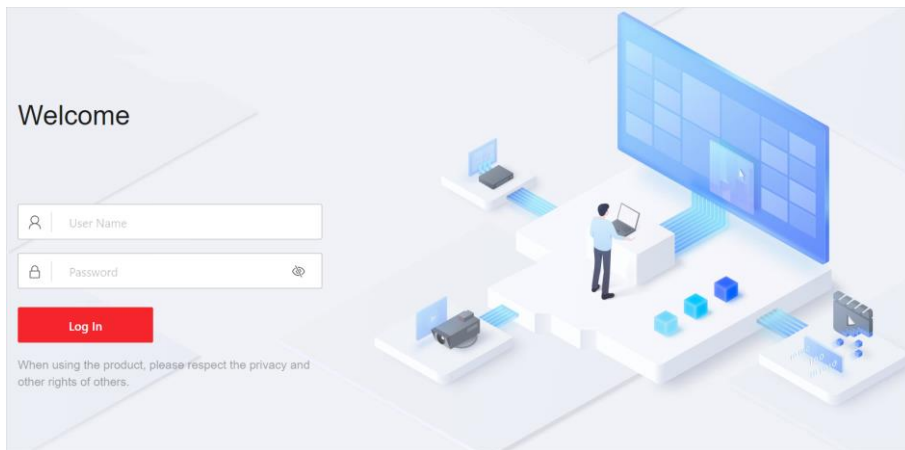

Figure 2-7 Login Page

Step 6 (Optional) To edit the password, you can click the username in the upper right corner of the web page and then click **Change Password**.

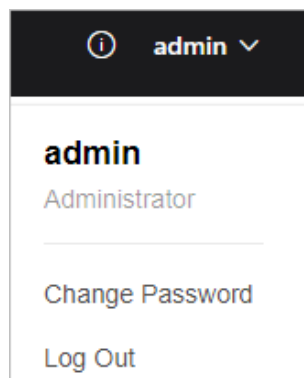
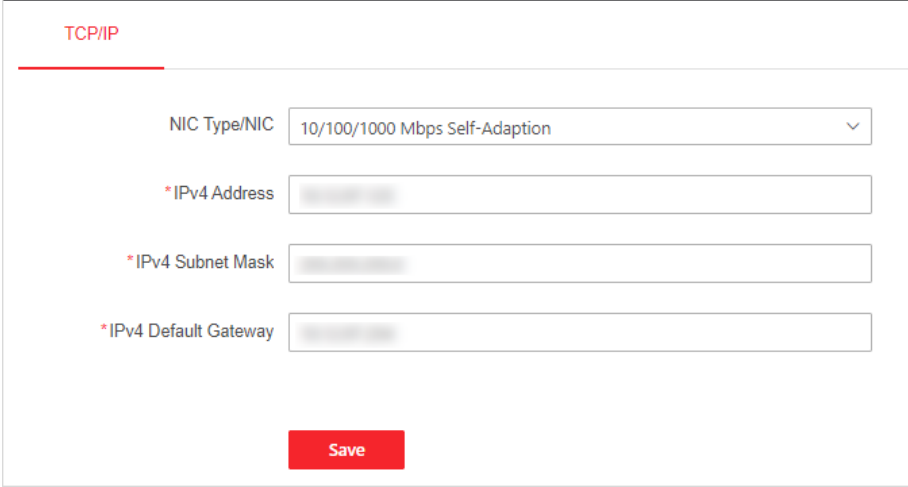

Figure 2-8 Change Password

2.3 Configure the Network Address

Step 1 Go to **Configuration** → **Network** → **Network Configuration** → **TCP/IP**.



The screenshot shows a web interface for configuring TCP/IP settings. At the top left, the text "TCP/IP" is displayed in red. Below this, there are four input fields: "NIC Type/NIC" with a dropdown menu showing "10/100/1000 Mbps Self-Adaption"; "*IPv4 Address"; "*IPv4 Subnet Mask"; and "*IPv4 Default Gateway". Each of the three address fields contains a blurred IP address. At the bottom center, there is a red "Save" button.

Figure 2-9 Configure the Device IPv4 Address

Step 2 Select the NIC type.

Step 3 Set the IPv4 address, IPv4 subnet mask, and IPv4 gateway for the device.

Make sure the device and the computer are in the same segment after the device connects to the on-site network.

Step 4 Click **Save**.

Step 5 (Optional) Remove the network cable that connects the device and computer, and use the network cable to connect the device to the on-site network.

Step 6 Enter the configured device IP address in the web browser of the computer to log in to the web page of the device.

Chapter 3 Video Wall Management

3.1 Configure Directly Connected LED Screens

Before configuring the LED video wall, configure the LED screens first.

- If the LED screens are directly connected to the LED controller board, configure the LED screens according to this section.
- If the LED screens are connected to the device through an external LED controller, configure the LED screens through the web interface of the LED controller, LED batch controller client, or LED Tool client.

3.1.1 Lighten the LED Screens

If the LED screens are directly connected to the LED controller board, you must lighten the screens. One LED controller board provides 1 output port.

Lighten General Screens

Step 1 On the **Video Wall Configuration** page, click  of the output port of an LED controller board.

Step 2 If the loading resolutions of multiple receiving cards controlled by a single LED controller board are consistent, select **General Configuration** as the configuration mode.

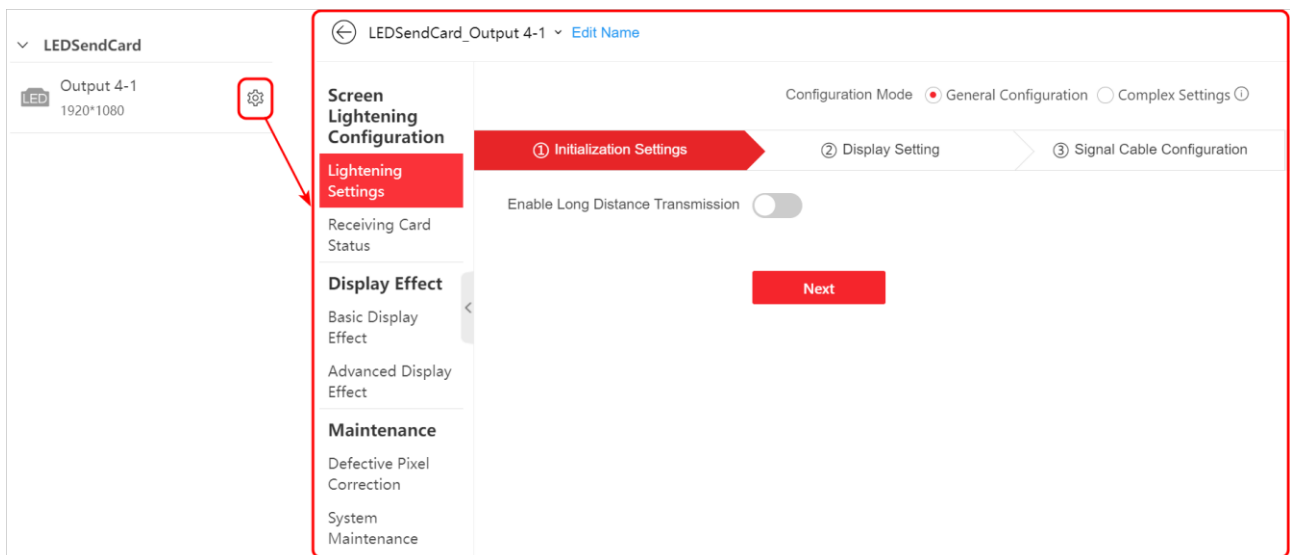



Figure 3-1 Select General Configuration

Step 3 (Optional) For long distance transmission, perform the following steps and click **Next**.

- 1) On the web page of the indoor device, enable long distance transmission and complete screen lightening.
- 2) On the web page of the outdoor device, enable long distance transmission.

Step 4 Configure the LED screens and click **Next**.

- 1) Set the screen size according to the receiving card quantity. Make sure the product of the screen column and screen row is equal to the actual receiving card quantity.
- 2) Select one of the following methods to import the receiving card configuration file:
 - Select **Load from Screen** and then click **Load**.
 - Select **Import File** and then click  to import a file.
 - Select **Load From Cloud**, enter the serial No., and click **Search**. Select a searched configuration file and then click **Load**.

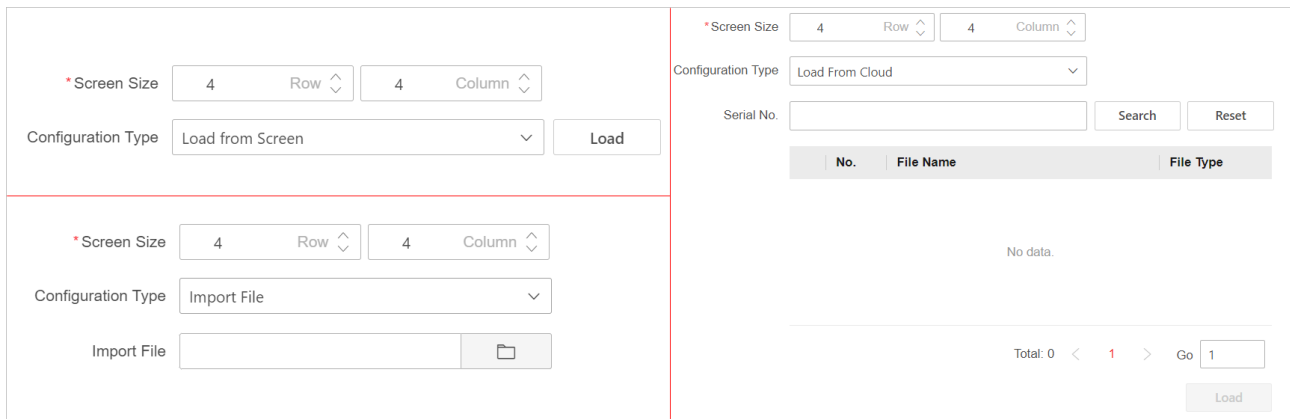

Figure 3-2 Configure General Screens

Step 5 Configure the signal cable connection.

- 1) Click **Show Connection** to display the network port number on the actual screens.
- 2) According to the network port number on the actual screens, select a network port of the LED controller board and then take either of the following methods to connect the selected network port to the screens:
 - Click to select screens and connect them in the order of operation. The connection can cross different network ports.
 - Click a screen to set as the start point of the connection and hold a screen to select the connection range. Batch connect screens in the order of operation. The connection can cross different network ports. If the start point and end point are not on the same row or column, the connection will be S-shaped in the order of operation.
- 3) Use the same method to connect other network ports to the screens.
- 4) (Optional) You can perform the following operations as required:
 - Click **Undo** to undo the previous operation.
 - Click **Restore** to restore the previous operation.

- Click **Clear Current Sending Port Connection** to clear the signal connection of the selected network port.
- Click **Clear All Sending Port Connection** to clear the signal connection of all network ports.
- Click **Hide Connection** to hide the network port on the actual screen.

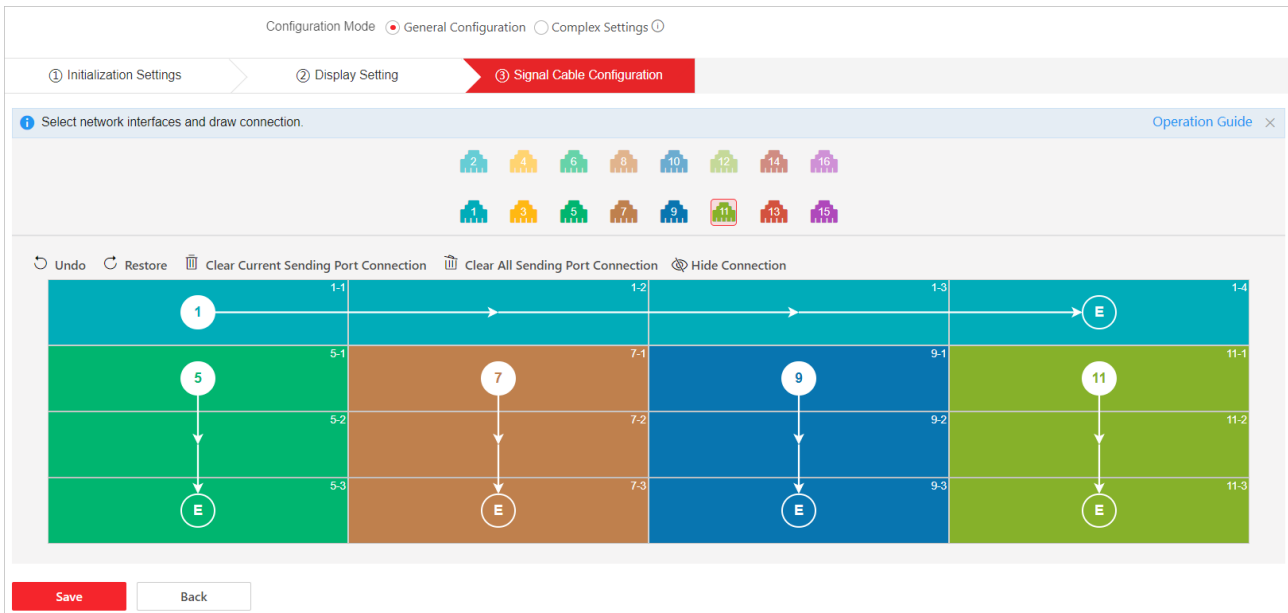



Figure 3-3 Configure Signal Cable Connection for General Screens

Step 6 Click **Save**.

Lighten Complex Screens

Step 1 On the **Video Wall Configuration** page, click  of the output port of an LED controller board.

Step 2 If the loading resolutions of multiple receiving cards controlled by a single LED controller board are inconsistent, select **Complex Settings** as the configuration mode.

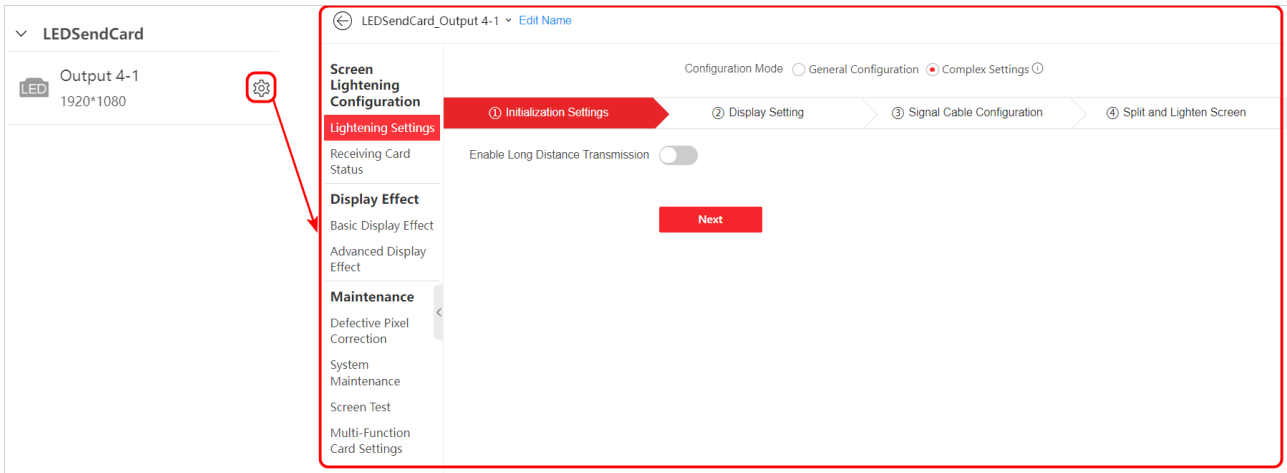

Figure 3-4 Select Complex Settings

Step 3 (Optional) For long distance transmission, perform the following steps and click **Next**.

- 1) On the web page of the indoor device, enable long distance transmission and complete screen lightening.
- 2) On the web page of the outdoor device, enable long distance transmission.

Step 4 Set the screen size according to the receiving card quantity, and then click **Next**.

Make sure the product of the screen column and screen row is equal to the actual receiving card quantity.

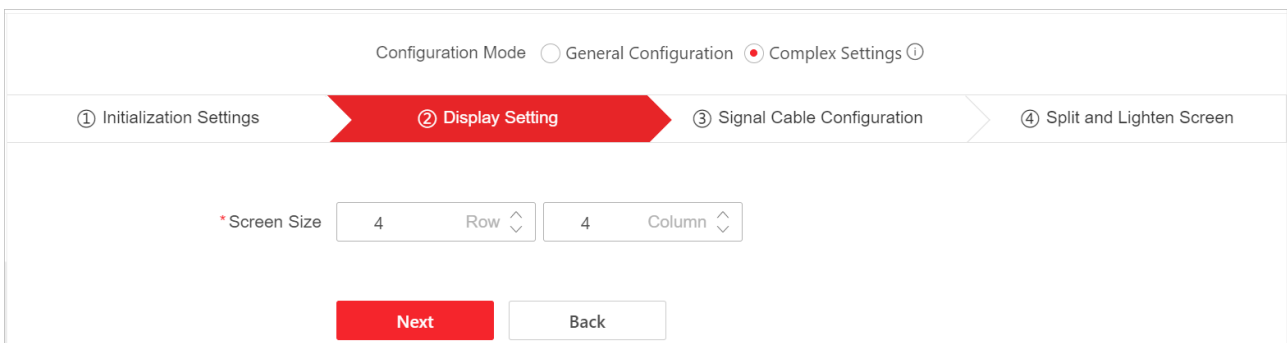

Figure 3-5 Configure Screen Size

Step 5 Configure the signal cable connection and click **Next**.

- 1) According to the actual cable connection of the LED screens and LED controller board, select a network port of the LED controller board, and then take either of the following methods to connect the selected network port to the screens:
 - Click to select screenings and connect them in the order of operation. The connection can cross different network ports.
 - Click a screen to set as the start point of the connection and hold a screen to select the connection range. Batch connect screens in the order of operation. The connection can cross different network ports of the device. If the start point and end point are

not on the same row or column, the connection will be S-shaped in the order of operation.

- 2) Use the same method to connect other network ports to the screens.
- 3) (Optional) You can perform the following operations as required:
 - Click **Undo** to undo the previous operation.
 - Click **Restore** to restore the previous operation.
 - Click **Clear Current Sending Port Connection** to clear the signal connection of the selected network port.
 - Click **Clear All Sending Port Connection** to clear the signal connection of all network ports.

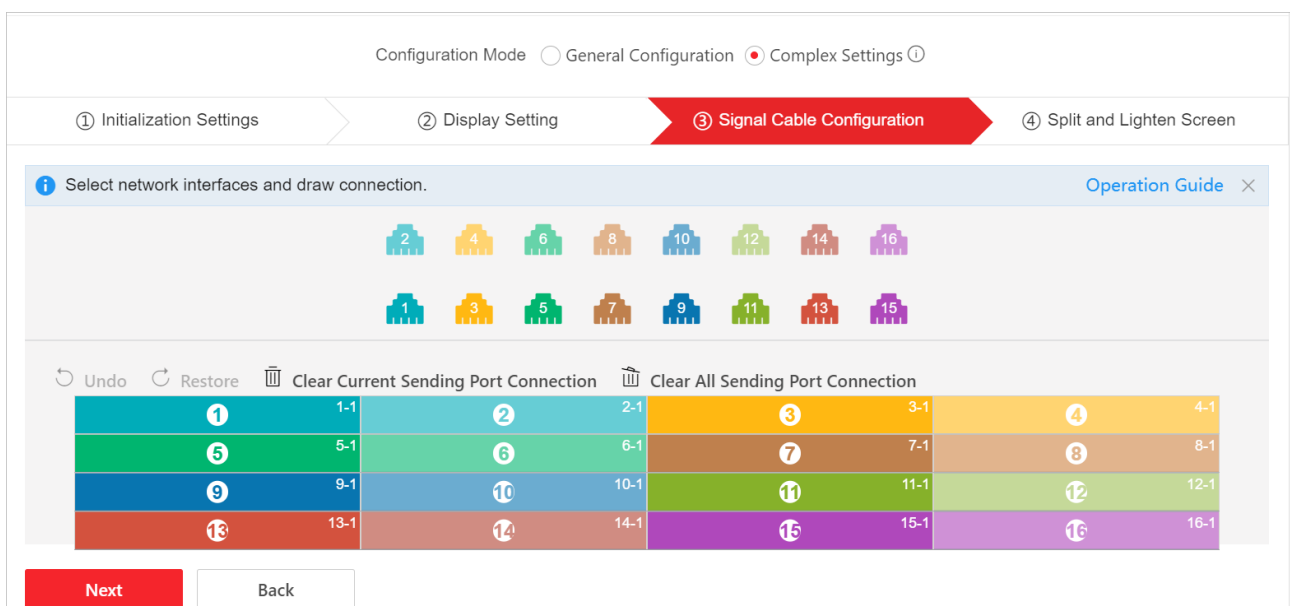



Figure 3-6 Configure Signal Connection for Complex Screens

Step 6 Split and lighten the screens.

- 1) Press and hold the left mouse button to draw a selection box around multiple screens.
- 2) Select one of the following methods to import the receiving card configuration file.
 - Select **Load from Screen** and then click **Load**.
 - Select **Import File**, click  to import a file, and then click **OK**.
 - Select **Load From Cloud**, enter the serial No., and click **Search**. Select a searched configuration file and then click **Load**.

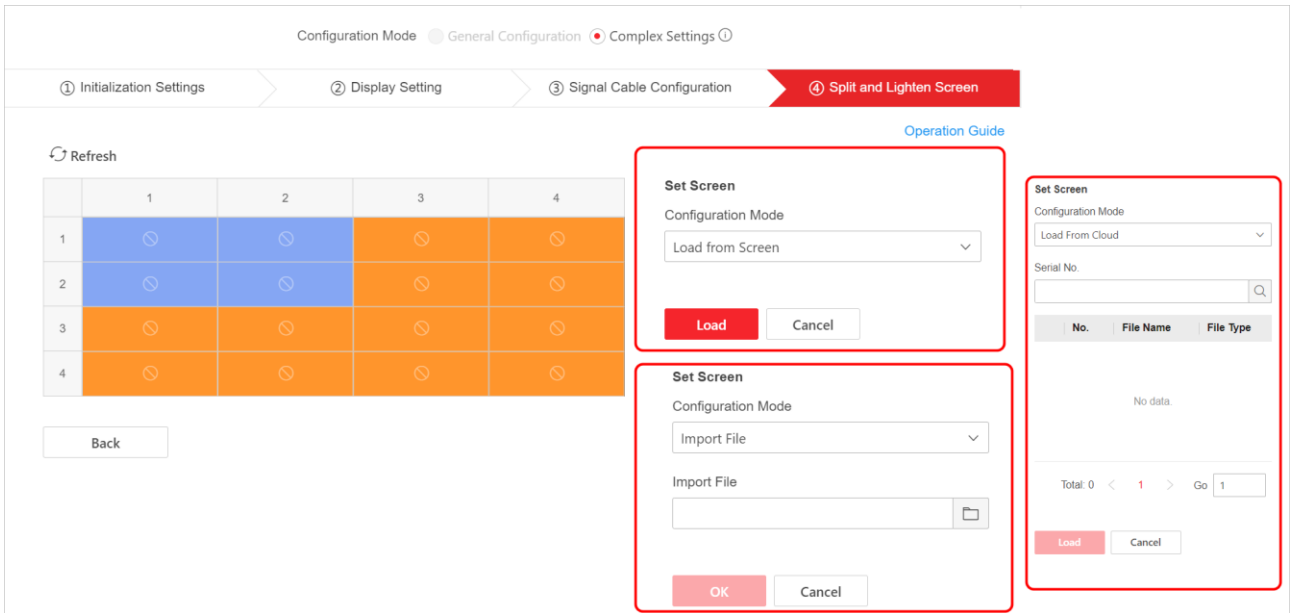



Figure 3-7 Split and Lighten a Complex Screen

3.1.2 Configure LED Controller Board

Go to **Video Wall Configuration**, click  of an output port of the LED control board to configure the following parameters as required.

Correct Receiving Cards

Step 1 Go to **Maintenance** → **Defective Pixel Correction**.

Step 2 Switch on **Enable Correction** at the top of the page to start configuring the correction parameters of the receiving cards.

If the screen supports bright hue correction, the bright hue correction will be enabled simultaneously after you enabling correction. It is recommended to enable the bright hue correction.

Step 3 Click  and select the area to be corrected.

If you need to correct modules, check **Show Module**.

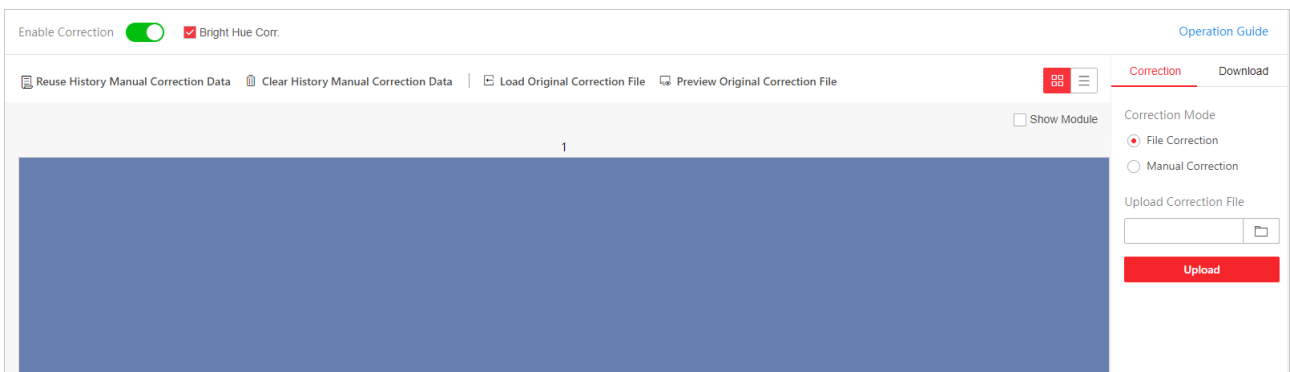

Figure 3-8 Select Correction Area

Step 4 Correct the receiving cards:

- 1) For the AXS receiving cards, click **Load Original Correction File** to load the factory correction data of the lamp board to the receiving cards.
 - You can click **Preview Original Correction File** to check the display effect of original correction file.
 - Loading the factory correction data is not required for the HUB receiving cards.
- 2) If the display effect still does not meet the requirements, select **File Correction** to load a locally saved correction file.
- 3) If the display effect still does not meet the requirements, manually correct the receiving cards:
 - When the color difference occurs, select **Manual Correction** and **Screen Correction**, and adjust the RGB (Red Green Blue) value. You can enable **Sync Adjustment** to adjust the RGB values simultaneously.
 - When seam lines occur, select **Manual Correction** and **Seam Correction**, set the seam direction and seam width, and adjust the RGB value. You can enable **Sync Adjustment** to adjust the RGB values simultaneously.

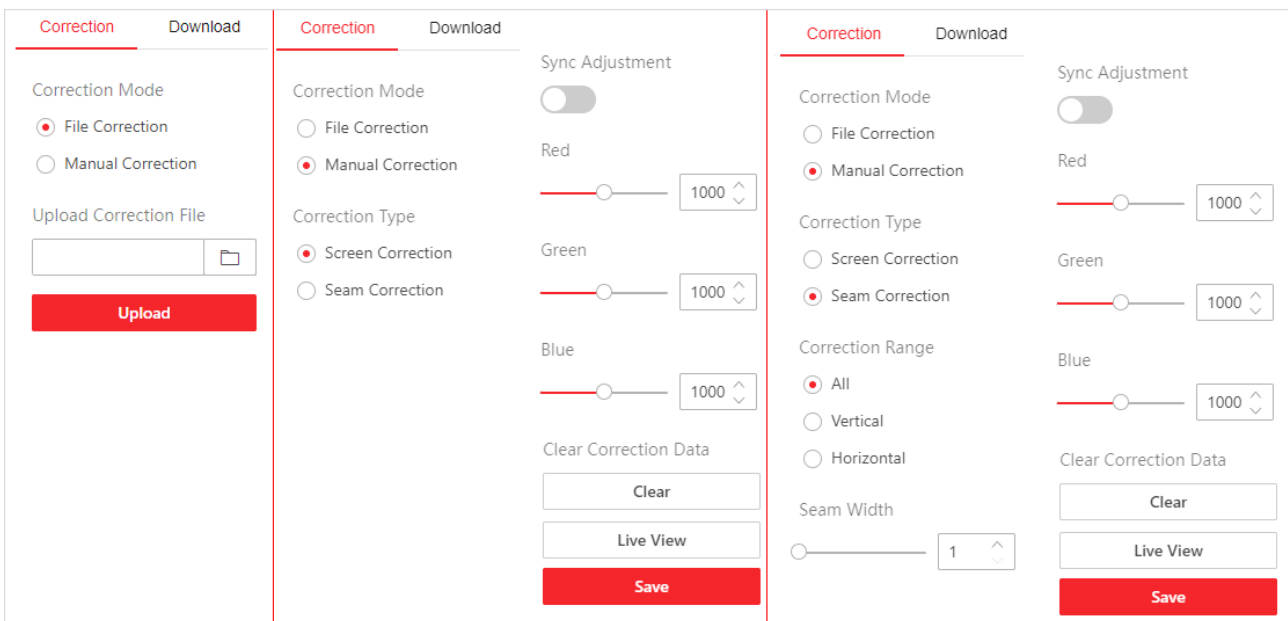

Figure 3-9 Correct Receiving Cards

Step 5 Click **Live View** to preview the display effect.

Step 6 When the desired display effect is reached, click **Save**.

Step 7 (Optional) You can perform the following operations as required:

- If the historical manual correction data do not meet the requirements, select the screen areas and click **Clear History Manual Correction Data**.
- If the display effect does not meet the requirements, select the screen areas and click **Clear**.

- To use the historical manual correction data to other screen areas, select the screen areas and click **Reuse History Manual Correction Data**.
- To export the correction data, select the screen areas, and click **Download** to download the correction data.

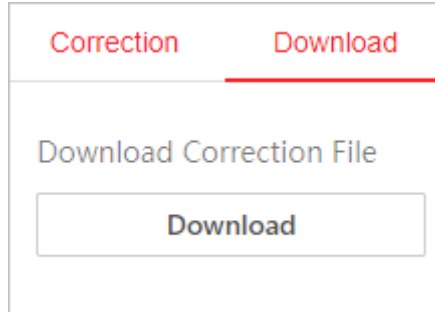



Figure 3-10 Download a Correction File

Configure Basic Display Effect

Step 1 Go to **Display Effect** → **Basic Display Effect**.

Step 2 Select a display mode.

Step 3 If the current display mode parameters do not meet the requirements, edit the corresponding parameters, and then click **Save**.

- Select a color standard:
 - The wide color gamut color standard is applicable to UHD devices.
 - The HDTV color standard is applicable to high definition televisions and other common video devices.
 - The digital cinema color standard is applicable to digital cinemas and high-end displays.
 - If you select the original color standard, the display will be restored to the original color.
 - The general color standard is applicable to the common displays.
- (Optional) Enable eye protection mode to reduce brightness and power consumption.
- Adjust the brightness. The manual adjustment is supported by default. To use the automatic adjustment, perform the following steps:
 - 1) Connect the light sensor to the multi-function card and connect the multi-function card to the LED controller board.
 - 2) Go to **Multi-Function Card Settings**, select **Light Sensor** for the corresponding channel, and set the sensor quantity.
 - 3) Click  to refresh the sensor settings.

Select Sensor Type

Channel No.	Sensor Type	Sensor Quantity	Status
1	Light Sensor	1	Offline
2	None	1	Offline
3	None	1	Offline
4	None	1	Offline

Sensor Threshold Settings

Cabinet Voltage Detection

Cabinet Temperature Detection

Ambient Temperature Detection

Ambient Humidity Detection

Auto Sleep

Save

Figure 3-11 Configure Light Sensor

- Adjust the color temperature.

Display Mode: General

Basic Parameter | **Advanced Parameter**

Color Standard: Original

Eye Protection Mode

Brightness Configuration

Brightness Adjustment Mode: Manual Adjustment

Brightness: 50

Color Temperature Configu...

Color Temperature Adjustment: Standard Color Temperature Fine Color Temperature

Color Temperature Mode: Warm Color Cool Color Standard Custom

Red: 43

Green: 33

Blue: 46

Save

Figure 3-12 Set Basic Display Effect

- Click **Advanced Parameter** to set the contrast mode, Gamma coefficient, environment brightness, and initial brightness.
 - A smaller Gamma coefficient makes the low gray areas brighter, while a larger Gamma coefficient makes the low gray areas darker.
 - When the ambient light is brighter, set a higher ambient brightness value.

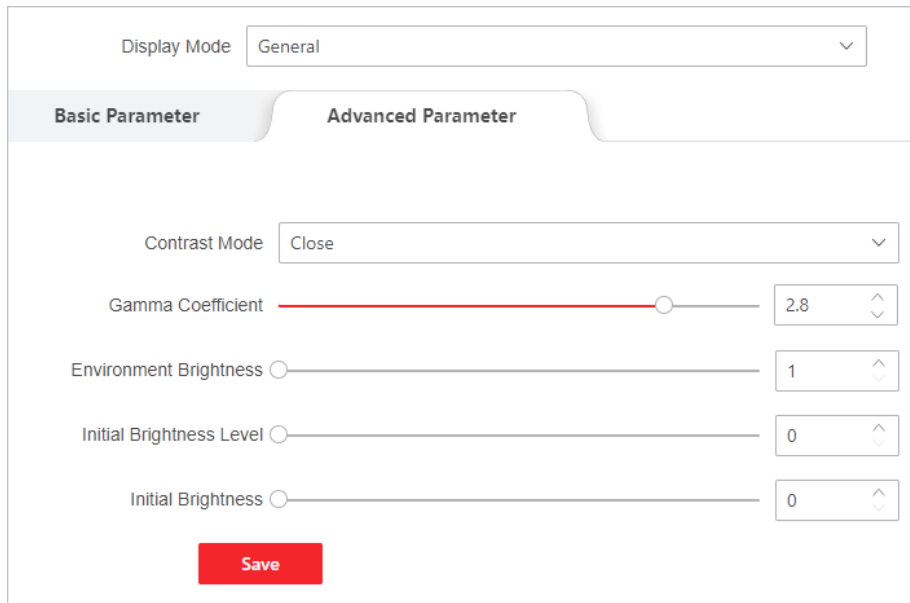

Figure 3-13 Set Advanced Display Effect

- Go to **Display Effect** → **Advanced Display Effect** → **Image Parameters**, enable **Ultra-Low Gray Control** to avoid low gray halos.
- Go to **Display Effect** → **Advanced Display Effect** → **Image Parameters**, enable **Gray Scale Optimization** to make the transition between grayscale levels become natural.

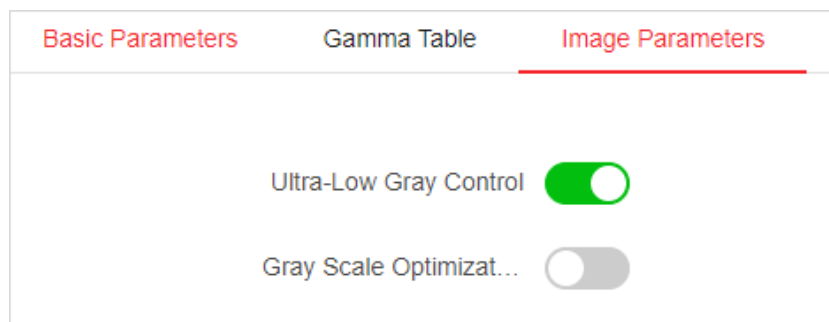

Figure 3-14 Set Image Parameters

View Display Effect

- Go to **Display Effect** → **Advanced Display Effect** → **Basic Parameters** to view the receiving card basic parameters.

You can enable **Open Circuit Detection** to eliminate the worm phenomenon of the LED screen.

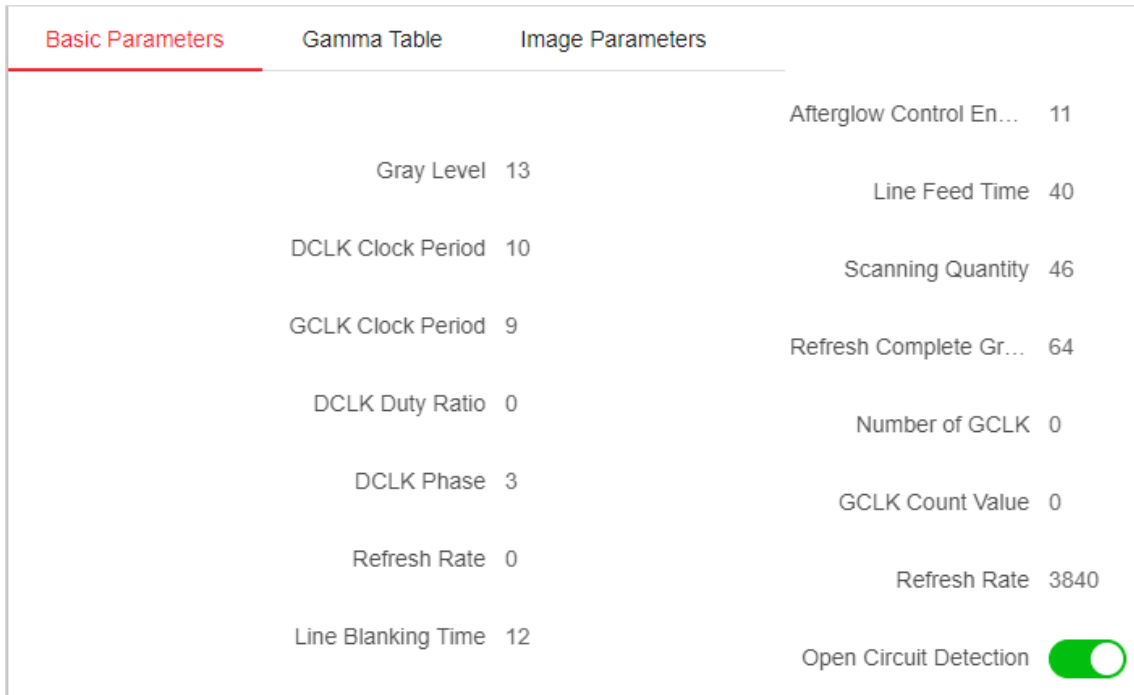

Figure 3-15 View Receiving Card Basic Parameters

- Go to **Display Effect** → **Advanced Display Effect** → **Gamma Table** to check whether the display effect parameters are correct.

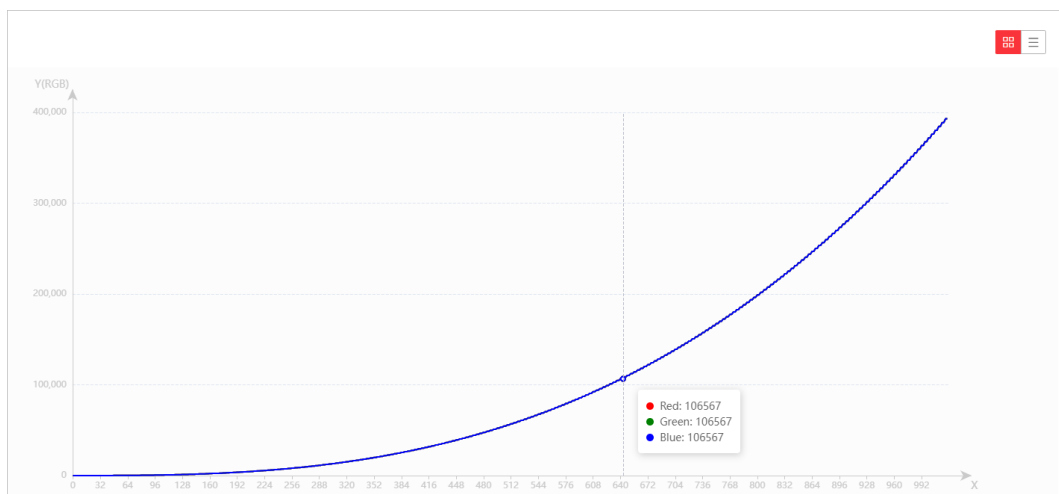

Figure 3-16 View Gamma Table

View Receiving Card Status

Go to **Screen Lightening Configuration** → **Receiving Card Status** to view the screen status and the network interface usage. You can hover over the receiving card to view its temperature, voltage, height and width.

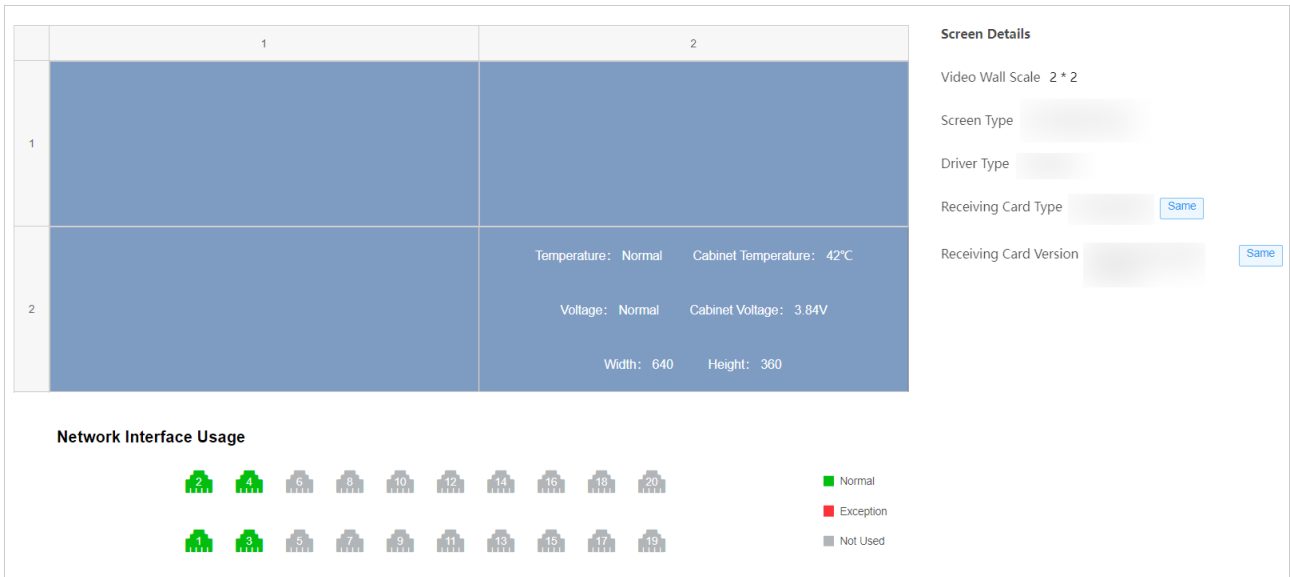

Figure 3-17 View Receiving Card Status

Test Screen Condition

Step 1 Go to **Maintenance** → **Screen Test**.

Step 2 Enable the screen test.

Step 3 Select an image to check whether the screen color is normal or whether the dead pixels exist.

- Select an existing color, or add a new color and select the new color. You can edit or delete the newly added color.
- Select a gray scale.
- Select a line.

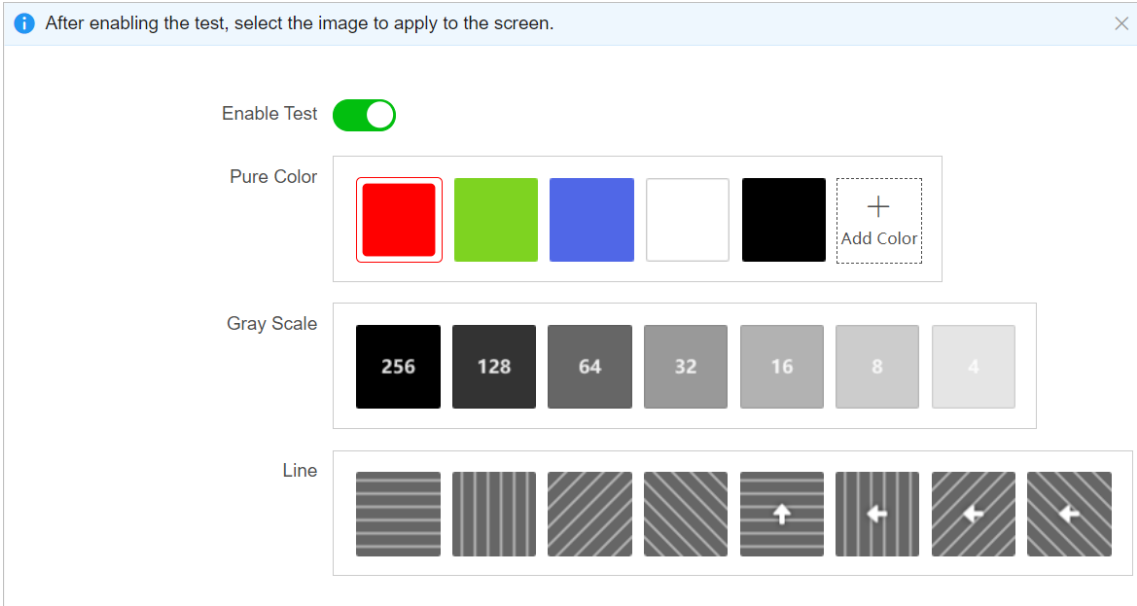



Figure 3-18 Test Screen Condition

Maintain LED Controller Board

- Click **Edit Name** to change the output port name.
- Go to **Maintenance** → **System Maintenance** → **Restart**, click **Restart** to restart the receiving card(s).
- Go to **Maintenance** → **System Maintenance** → **Upgrade**, click  to select an upgrade file, and click **Upgrade** to upgrade the receiving card(s).
- Go to **Maintenance** → **System Maintenance** → **Backup and Reset**, export the receiving card debug file, export the receiving card configuration file, or import the LED controller configuration file.

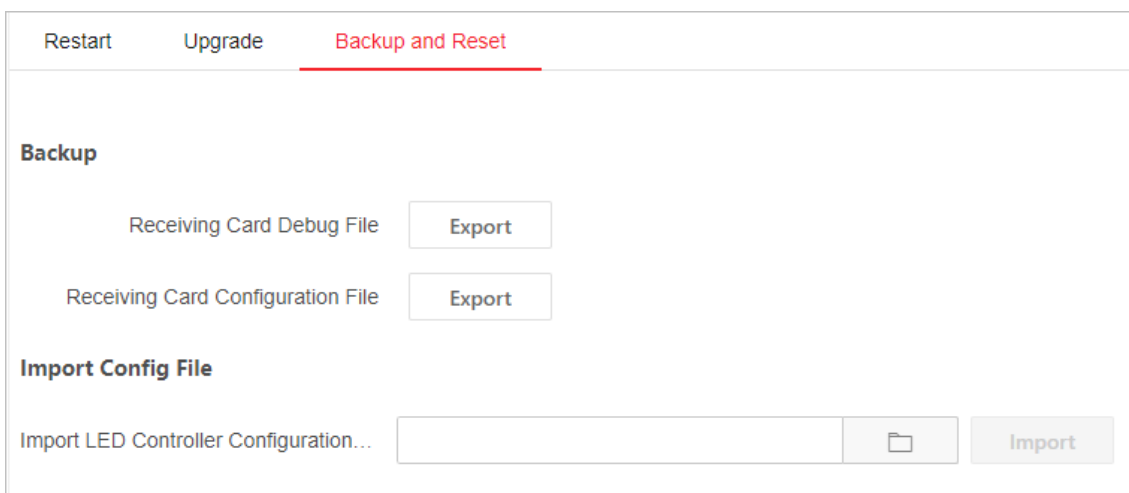



Figure 3-19 Backup and Reset Page

3.1.3 Configure Multi-Function Card

Configure Sensors

Step 1 Go to **Video Wall Configuration**, and click  of an output port of the LED control board.

Step 2 Go to **Multi-Function Card Settings** → **Sensor Settings** to monitor the following items, and click **Save**. When an item reaches the threshold, the screen will display the alarm information and the current value of the monitored item.

- Some receiving cards support detecting the cabinet voltage and cabinet temperature. Enable **Cabinet Voltage Detection** and **Cabinet Temperature Detection**, and set the thresholds.
- When the LED controller board is connected to the multi-function card, and the multi-function card is connected to the temperature and humidity sensor, you can monitor the environmental temperature and humidity.
 - 1) Select **Temperature and Humidity Sensor** for the corresponding channel and set the sensor quantity.
 - 2) Click  to refresh the sensor settings.

- 3) Enable **Ambient Temperature Detection** and **Ambient Humidity Detection**, and set the thresholds.
- When the LED controller board is connected to the multi-function card, and the multi-function card is connected to the human body sensor, you can set the auto sleep function.
 - 1) Select **Human Body Sensor** for the corresponding channel and set the sensor quantity.
 - 2) Click  to refresh the sensor settings.
 - 3) Enable **Auto Sleep**.
 - 4) Set the brightness reduction time, OSD prompt time, and sleep time.

Select Sensor Type 

Channel No.	Sensor Type	Sensor Quantity	Status
1	Temperature and Humidity v	1 ^ v	✘ Offline
2	Light Sensor v	1 ^ v	✘ Offline
3	Human Body Sensor v	1 ^ v	✘ Offline
4	None v	1 ^ v	✘ Offline

Sensor Threshold Settings

Cabinet Voltage Detection

* Max. Voltage V

* Min. Voltage V

Cabinet Temperature Detection

* Cabinet Temperature Threshold °C

Ambient Temperature Detection

* Ambient Temperature Threshold °C

Ambient Humidity Detection

* Ambient Humidity Threshold %RH

Auto Sleep

* Brightness Reduction Time s

* OSD Prompt Time s

* Sleep Time s

Save

Figure 3-20 Configure Sensors

Configure Power Distribution Cabinet

When the LED controller board is connected to the multi-function card, and the multi-function card is connected to the distribution cabinet, you can control the status of the power distribution cabinet remotely.

Step 1 Go to **Video Wall Configuration**, and click  of an output port of the LED control board.

Step 2 Go to **Multi-Function Card Settings** → **Power Distribution Cabinet Settings**, use either of the following methods to control the power distribution cabinet and click **Save**.

- Set immediate power on or off:
 - Enable the circuit that is connected to the power distribution cabinet to power on the power distribution cabinet. Disable the circuit to power off the power distribution cabinet.
 - (Optional) When one multi-function card is connected to multiple power distribution cabinets, it is recommended to enter the device name.

Wiring Method

Dry Contact

Power Distribution Cabinet Status

Power Cir...	Device Name	Status
Circuit 1	<input type="text" value="/"/>	<input checked="" type="checkbox"/>
Circuit 2	<input type="text" value="/"/>	<input type="checkbox"/>
Circuit 3	<input type="text" value="/"/>	<input type="checkbox"/>

Timer List

Timed On/Off

+ Add  Clear

Date	Start Time - End Time	Closed Circuit	Operation
No data.			

Save

Figure 3-21 Immediate Power On/Off

- Set timed power on or off:
 - 1) Click **Add** to add the timer and click **Save**.

2) Enable **Timed On/Off**.

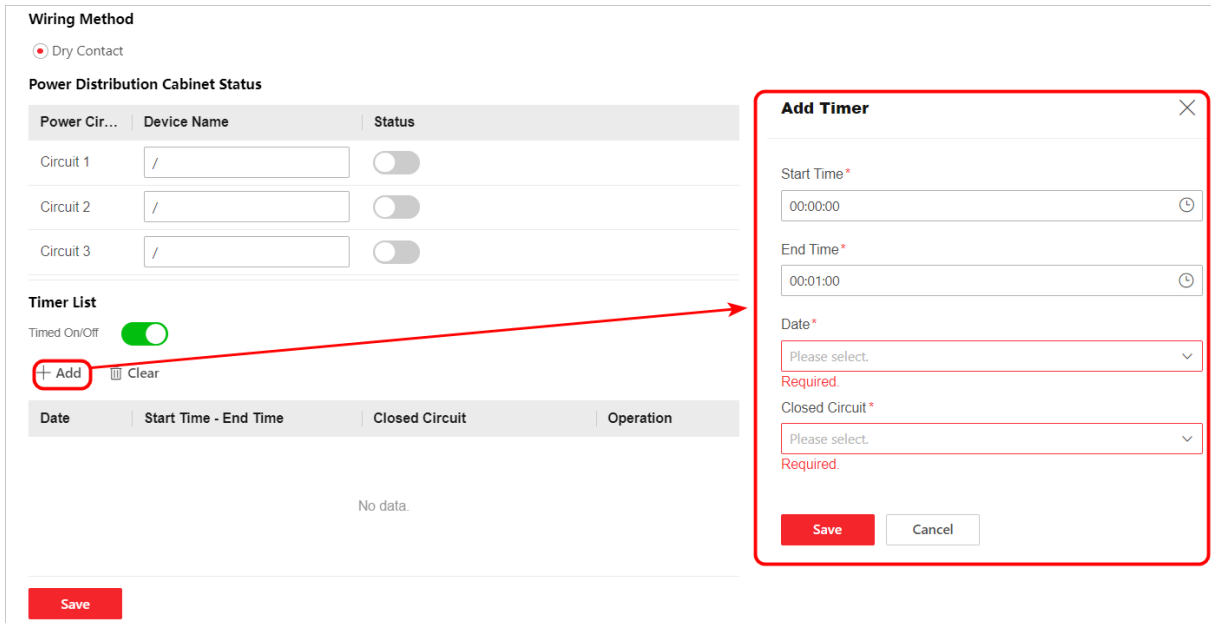

Figure 3-22 Set Timed Power On/Off

3.2 Configure a Video Wall

3.2.1 Configure the Video Wall Scale

Step 1 Go to **Video Wall Configuration**, select a video wall in the upper left corner and click **Configure**.

You can click **Edit Name** to change the video wall name.

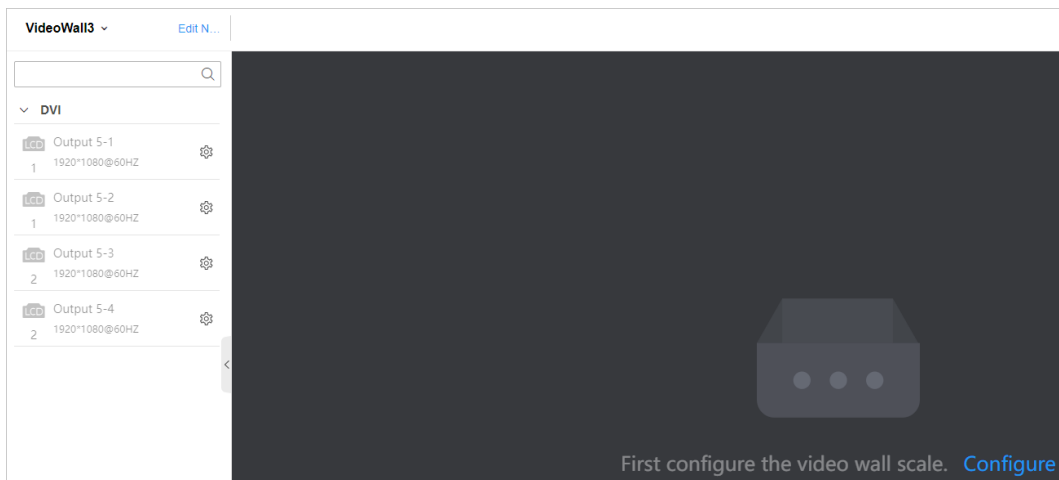

Figure 3-23 Video Wall Configuration Page

Step 2 According to the actual screen type, select the video wall type. You can select LCD or LED.

Step 3 Choose either of the following methods to set the video wall scale:

- Directly enter the row number and column number.
- Move the mouse and click the left button to select the screen area.
- To edit the video wall scale, directly enter a new row number and a new column number.
- To edit the video wall scale, click **Clear**, move the mouse, and then click the left button to select the screen area.

Step 4 Select a decoding output resolution, and click **Save**.

- For an LCD video wall, select a defined resolution. Thus, all LCD screens of the current video wall use the selected resolution.
- For an LED video wall, select a defined resolution or select **Custom**, and then enter the row height and column width. If you select a defined resolution, the entered row height and column width cannot exceed the selected defined resolution. After entering the row height and column width, the height of the same row and width of the same column are the same.

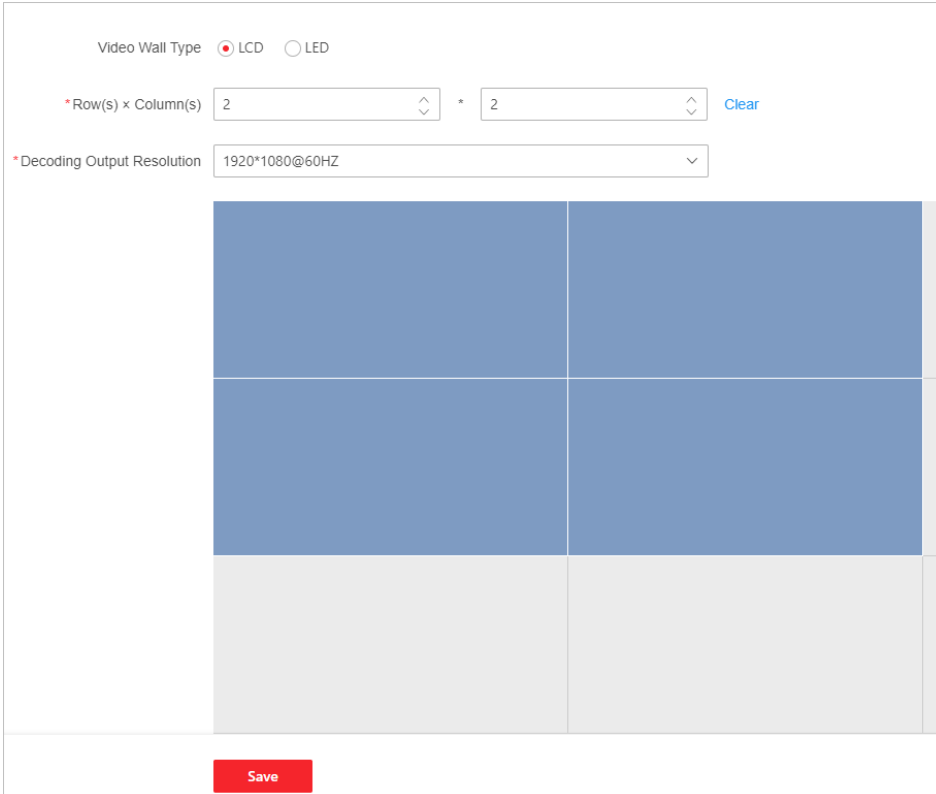

The screenshot displays the configuration interface for a video wall. At the top, there are radio buttons for 'Video Wall Type' with 'LCD' selected. Below this, there are two input fields for '* Row(s) x Column(s)' with the value '2' entered in both, and a 'Clear' button to the right. Underneath, there is a dropdown menu for '* Decoding Output Resolution' with '1920*1080@60HZ' selected. The main area of the interface shows a 2x2 grid of blue rectangles representing the video wall layout. At the bottom center, there is a red 'Save' button.

Figure 3-24 Select a Decoding Output Resolution

Step 5 (Optional) To set an LED video wall that uses varied height of the same row or varied width of the same column, set the special resolution.

- 1) Go to **Configuration** → **Other Settings** → **Display Settings**, enable special resolution.

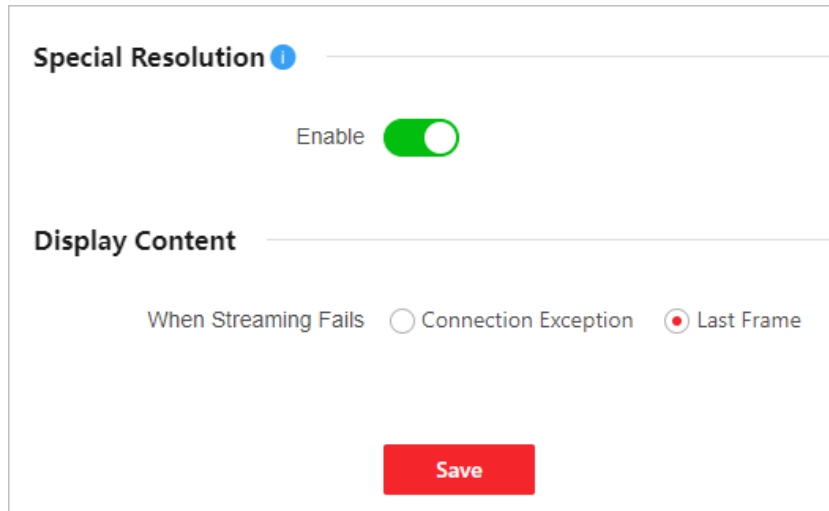



Figure 3-25 Enable Special Resolution

- 2) Select a defined resolution or select **Custom**, enter the row height and column width.
 - If you select a defined resolution, the entered row height and column width cannot exceed the selected defined resolution.
 - You can click  to copy the value to the same row or column.

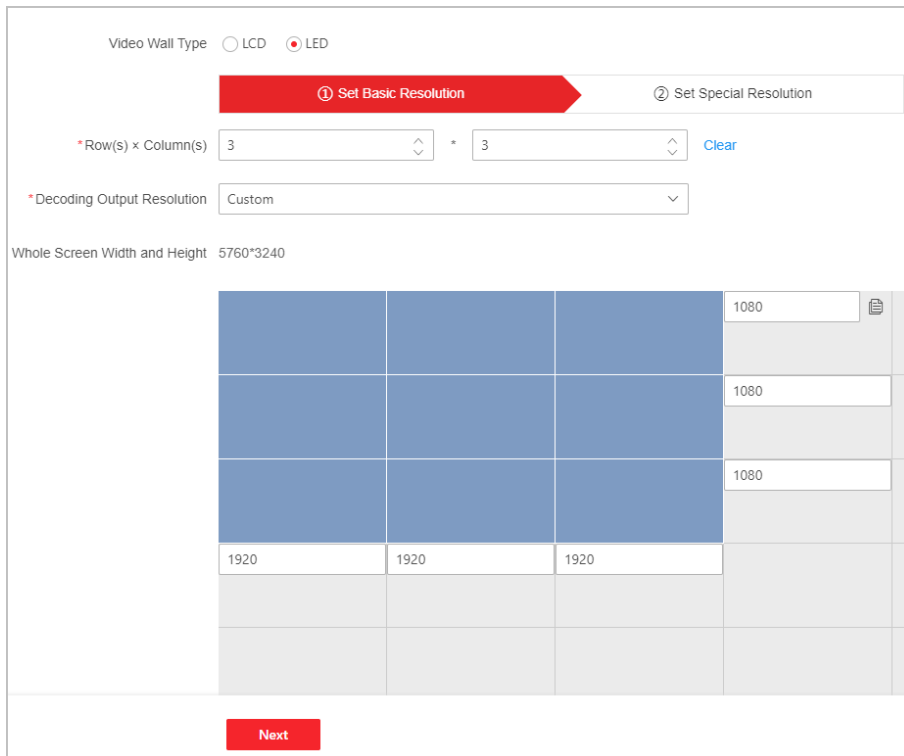

Figure 3-26 Set the Basic Resolution

- 3) Click **Next**.

- 4) Press and hold the left mouse button to select the first row, first column, last row, or last column, enter the column quantity, row quantity, row height, or column width, and then click **OK**.
 - The total resolution of the selected area cannot change.
 - Merging rows or columns reduces the number of screens on the current video wall, so you need to increase the column width or row height.



Figure 3-27 Set Special Resolution

- 5) Click **Save**.

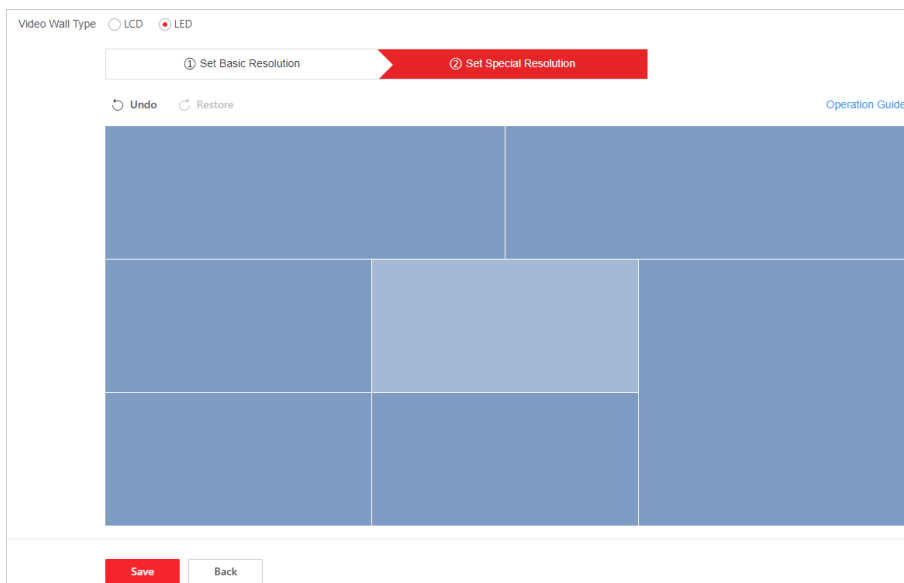

Figure 3-28 Save Special Resolution

Step 6 (Optional) After setting the video wall scale, you can click **Edit Video Wall Scale** to change the video wall scale.

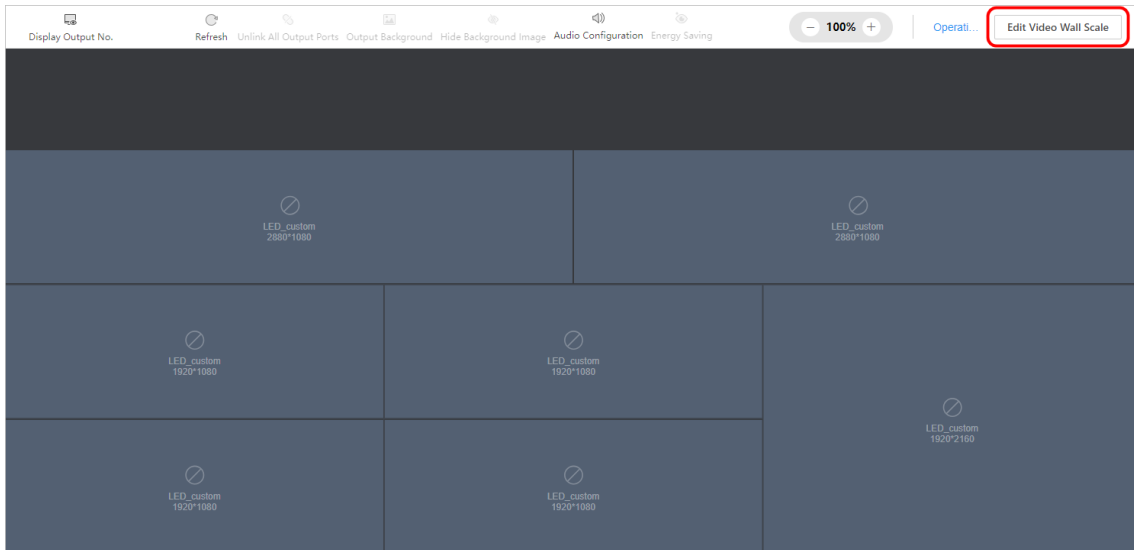



Figure 3-29 Edit the Video Wall Scale

3.2.2 Configure the Output of a Video Wall

Edit the Output Port Parameters

On the **Video Wall Configuration** page, click  of an output port of an output board to configure the following items:

- Customize the name.
- Edit the output mode of an HDMI output port: By default, the HDMI mode is used. For better compatibility, you can change it to DVI mode.
- Copy the current HDMI output configuration to other output ports: Click **Copy To** and then select the output ports.

Output Port Settings ✕

Decoding Output Name*

Output Mode Settings

Output Mode

Save
Copy To
Cancel

Figure 3-30 Configure HDMI Output Port

Bind Output Ports with Video Wall

A video wall can contain one screen or multiple screens. At a time, one screen can join only one video wall, and one output port can be bound with only one screen.

Step 1 On the **Video Wall Configuration** page, click **Display Output No.** to display the output port number on the actual screen.

This function is not available for the LED controller board.

Step 2 According to the output number shown on the actual screen, drag the corresponding output ports to the screens of the video wall.

- To batch bind output ports with the video wall, press **Ctrl** to select multiple output ports and drag the output ports to the screens of the video wall.
- To cancel the linkage between a screen and an output port, click  in the upper right corner of the screen.
- To cancel the linkage between all screens and output ports, click **Unlink All Output Ports**.

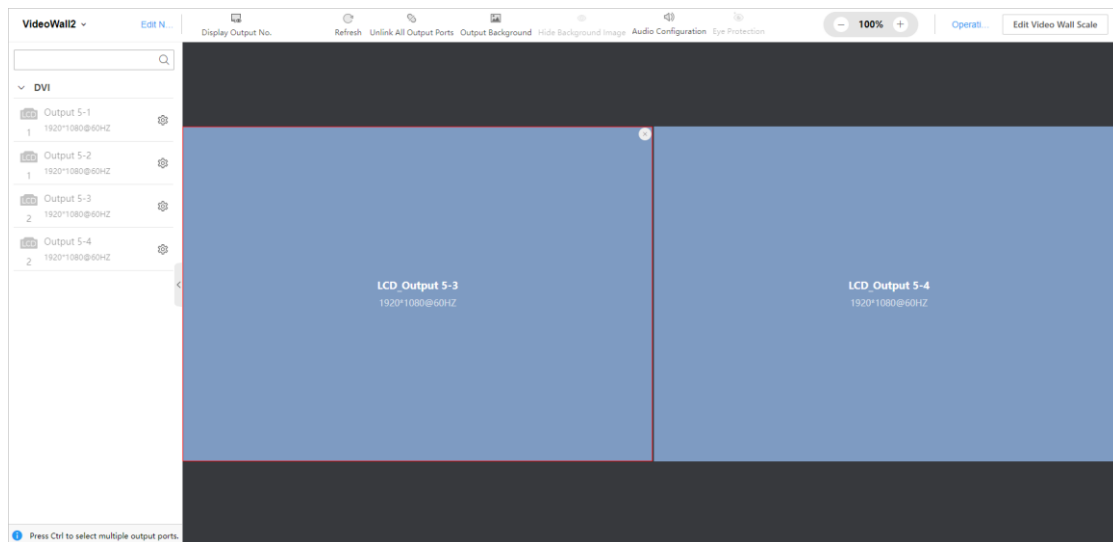

Figure 3-31 Bind Output Ports with Video Wall

Step 3 (Optional) If the screens that are used to configure the video wall support control linkage function, you can perform the following operations to auto bind output ports to the screens of the video wall.

- 1) Make sure all screens are enabled with the control linkage function.
- 2) Use the remote control to set the location information for all actual screens.

3) Click **Edit Wall Scale** and select **Auto Configure**.

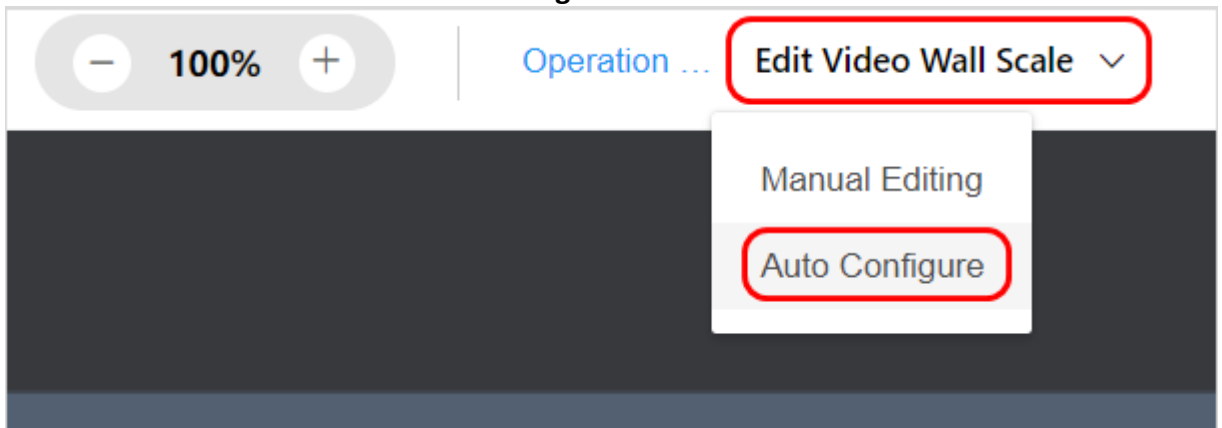



Figure 3-32 Auto Bind Output Ports with Screens

Configure Audio Matrix

If you need to configure multiple audio outputs for a video wall, configure the audio matrix.

Step 1 On the **Video Wall Configuration** page, click **Audio Configuration** and select **Audio Matrix**.

Step 2 Double click to link the audio input channel and audio output channel.

Double click again or click  to unlink.

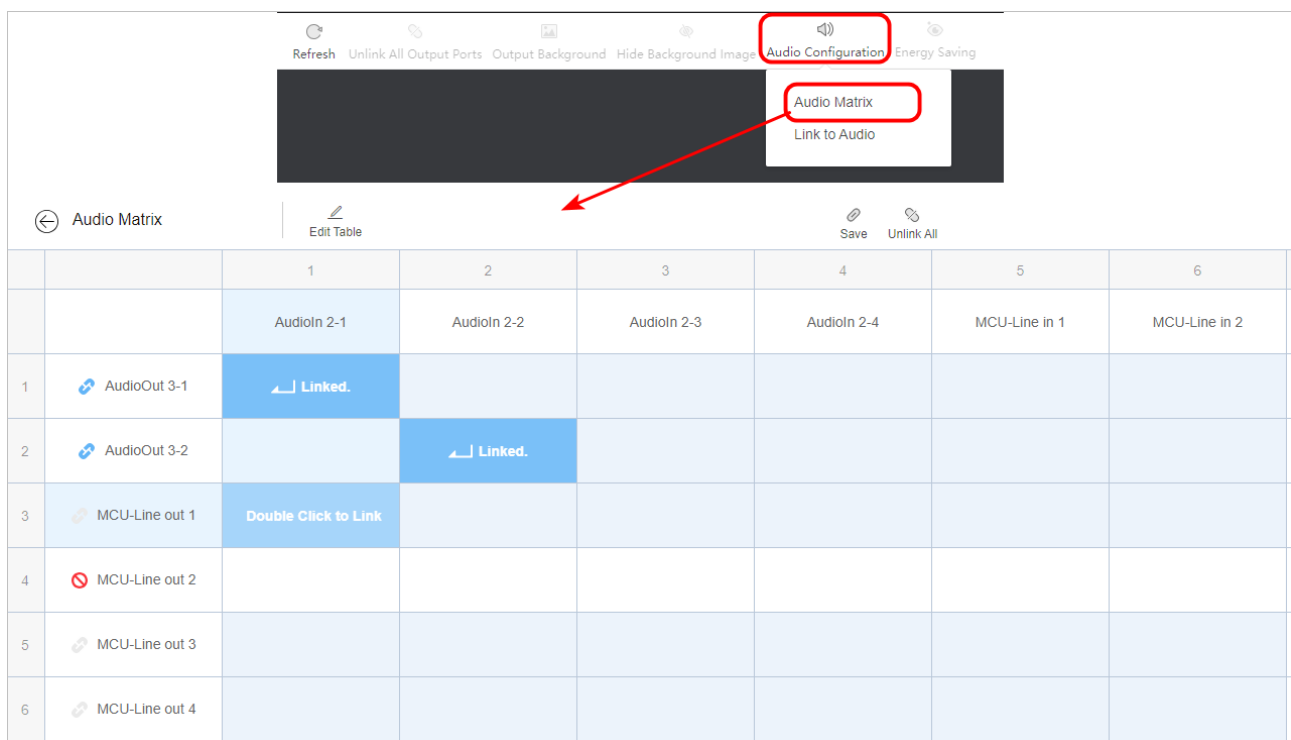

Figure 3-33 Configure Audio Matrix

Step 3 (Optional) You can perform the following operations as required:

- Double click the name of an audio channel to edit its name.

- Click **Edit Table** to customize the audio channel name and configure the displaying of the audio channel in the table.

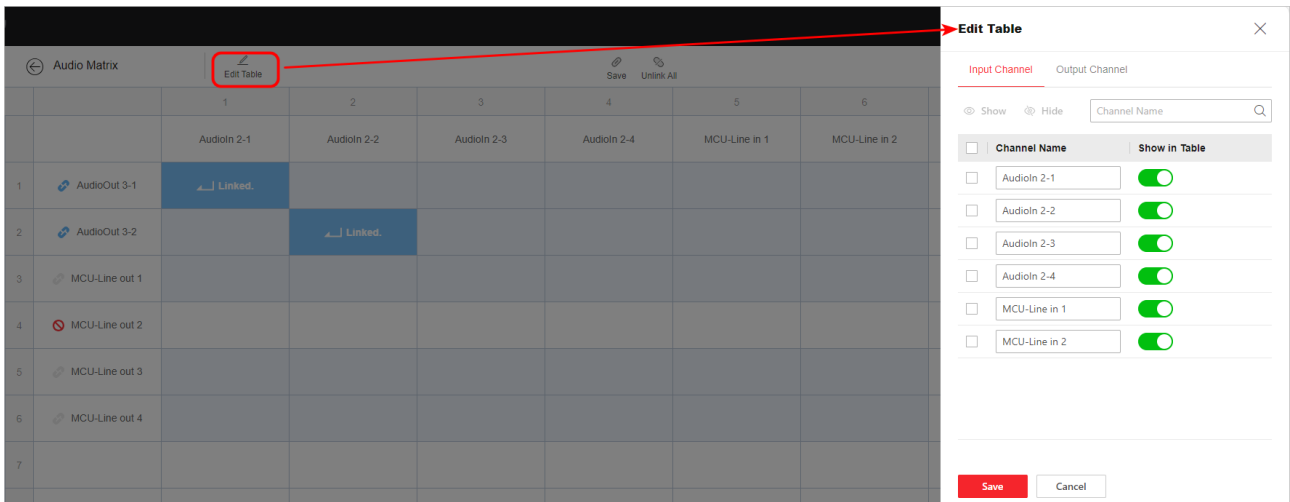



Figure 3-34 Edit Audio Channel Table

- Click **Unlink All** to unlink all audio linkage.

Step 4 Click **Save**.

Configure an Audio Output

On the **Video Wall Configuration** page, click **Audio Configuration** and select **Link to Audio**. Click  at the upper right corner of an audio output to set it as the audio output of the video wall.

- After setting the audio output of a video wall, you need to go to the **Video Wall Operation** page to enable audio to allow the audio output.
- One video wall can be linked with only one audio output.

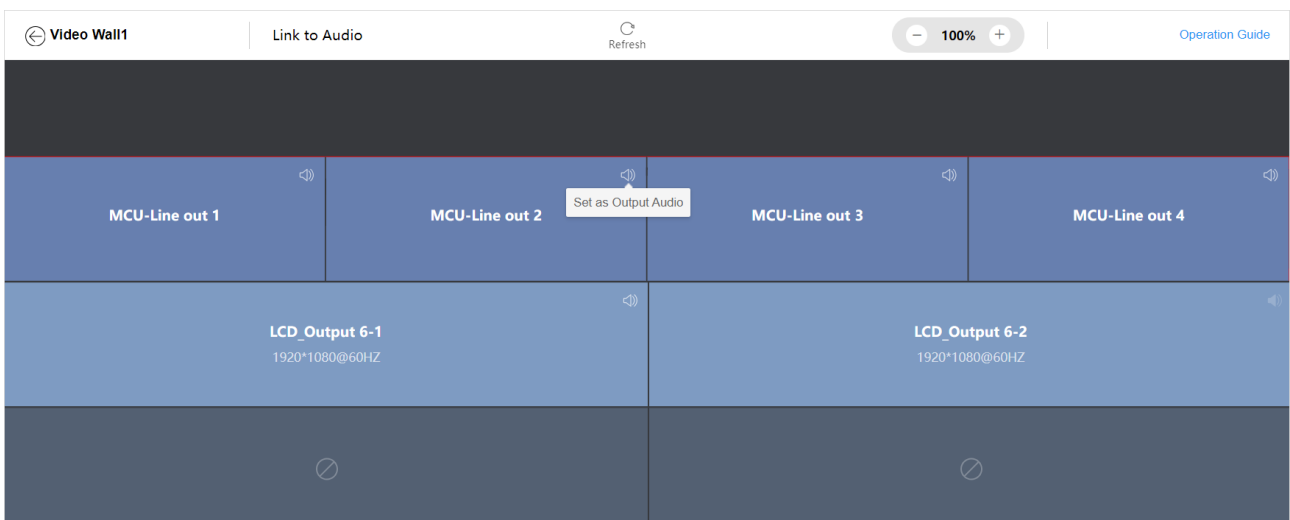

Figure 3-35 Set Output Audio

Configure Other Output Parameters

At the top of the **Video Wall Configuration** page, you can perform the following operations as required:

- Click **Output Background** to edit the background color or import images.

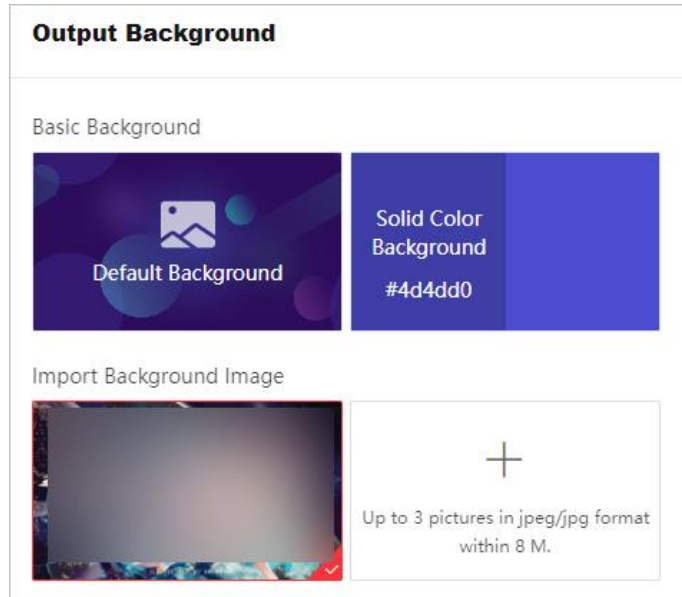

Figure 3-36 Edit Output Background

- After importing an image as the background, you can click **Hide Background Image** or **Show Background Image**.
- Click **Edit Name** to change the video wall name.
- Only the LED controller board supports the energy saving function. Bind the output port of an LED controller board to the video wall, click **Energy Saving**, and then enable energy saving and set the strength coefficient.

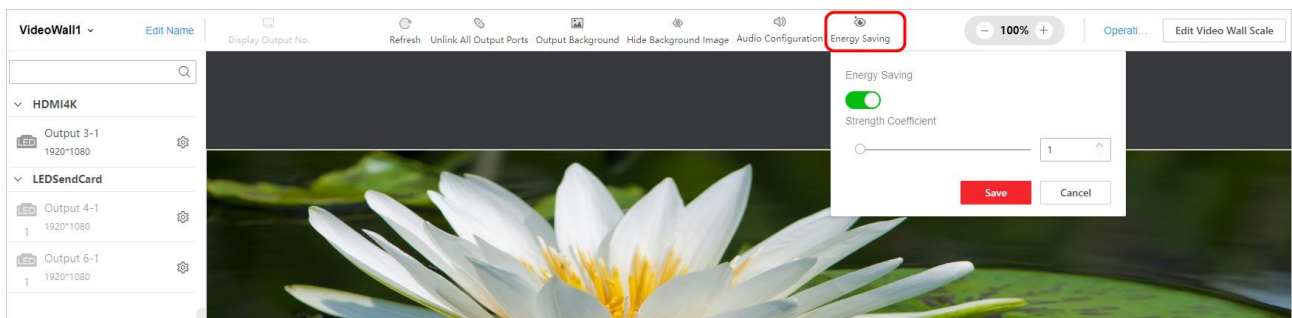

Figure 3-37 Set Eye Protection

3.2.3 Manage Signal Sources

Add a Network Signal Source via IP Address

Step 1 Go to **Video Wall Operation** → **Source**, click , and select **IP Address**.

Step 2 Enter the signal source information and stream media information.

- Click **More** to select the transmission protocol, stream type, encrypted stream, device manufacturer, and streaming media information.

After enabling **Get Stream via Streaming Server**, you can perform live view data forwarding through the streaming server to reduce network stress.

- If you add an NVR or IPC that has multiple channels, all channels of the NVR or IPC will be automatically added to the device.

Figure 3-38 Add a Network Signal Source via IP Address

Step 3 Click **Save**.

Add a Network Signal Source via URL Address

Step 1 Go to **Video Wall Operation** → **Source**, click , and select **URL**.

Step 2 Enter the device name and the URL address.

Figure 3-39 Add a Network Signal Source via URL Address

Step 3 Click **Save**.

Batch Delete Network Signal Sources

To batch delete invalid network signal sources, you can select multiple network signal sources with **Ctrl** or **Shift** pressed and then click .

3.2.4 Bind Signal Sources with a Video Wall

Go to **Video Wall Operation** and then select a video wall. Take either of the following methods to bind signal sources with the video wall:

- Select a signal source and then drag it rightward to the video wall.
 - If you bind a signal source to an LCD video wall, the signal source window fully covers a single screen by default.
 - If you bind a signal source to an LED video wall, the signal source window fully covers the LED video wall by default.

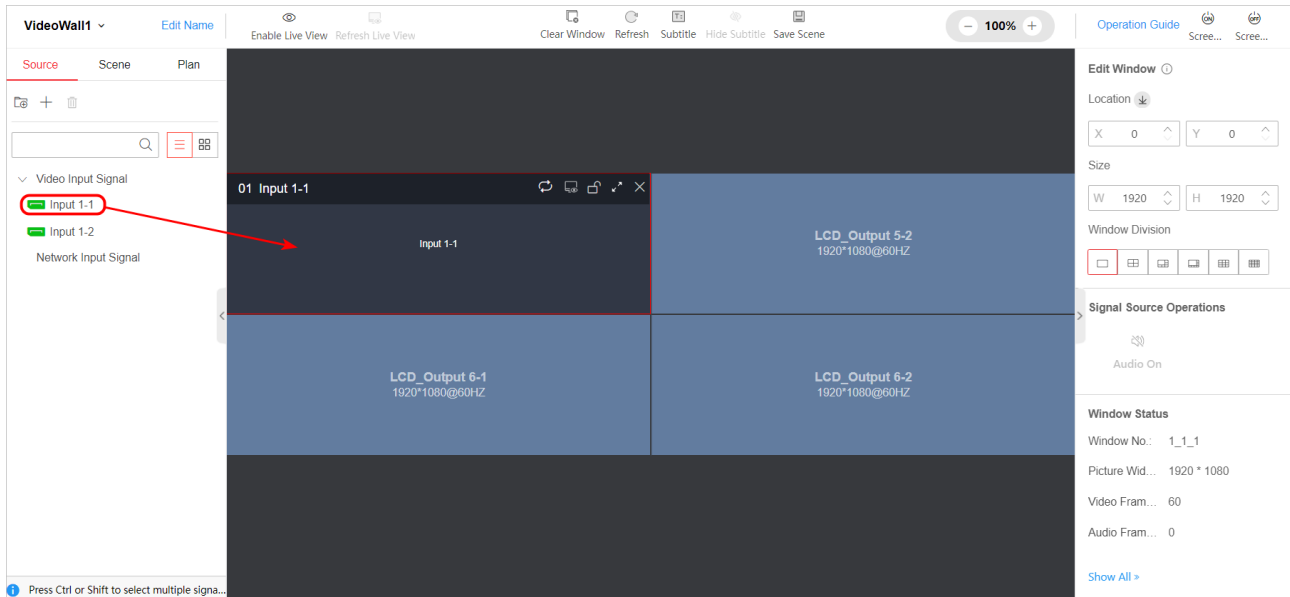

Figure 3-40 Bind a Signal Source to LCD Video Wall

- Drag a default signal source group or a newly created signal source group rightwards to the video wall.
 - By default, the local signal sources join the video input signal group and the added network signal sources join the network input signal group.
 - Before dragging a network signal source to the video wall, make sure that the decoding board is in the device.
 - To create a new signal source group, see Create a Signal Source Group.
- Batch bind multiple signal sources:
 - Press **Ctrl** or **Shift** to select multiple network signal sources of the same signal source group, and drag signal sources rightward to the video wall.
 - Press **Ctrl** to select multiple local signal sources of the same signal source group, and drag signal sources rightward to the video wall.

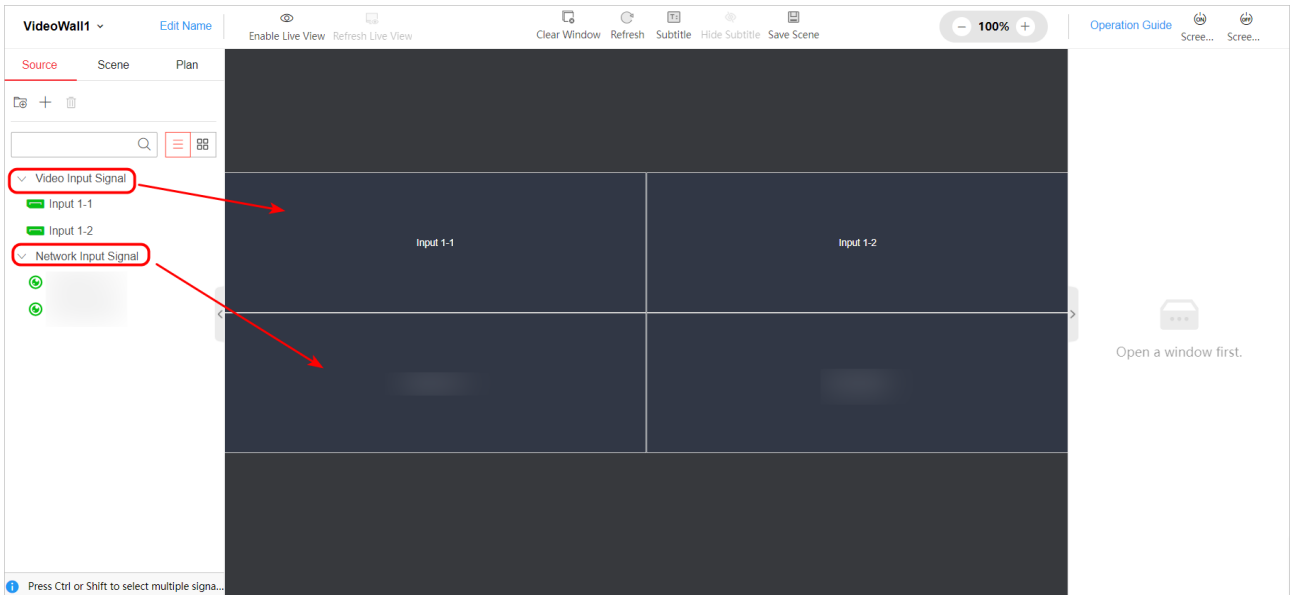



Figure 3-41 Batch Bind Signal Sources to Video Wall

Create a Signal Source Group

The combination of network signal sources and local signal sources in the same signal source group is not supported.

Step 1 Click  and enter the group name.

Step 2 Click  to add multiple signal sources to the created group.

Step 3 Click **OK**.

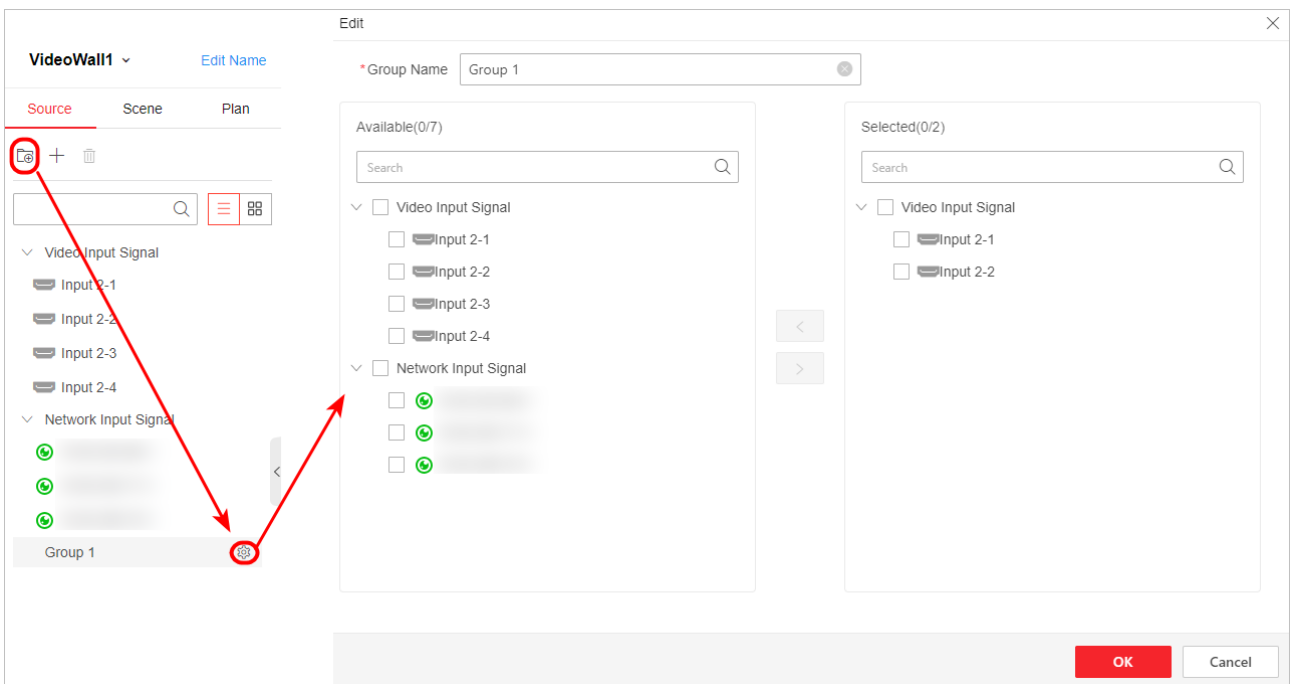





Figure 3-42 Create Signal Source Group

3.3 Operate a Video Wall

3.3.1 Edit Signal Source Window Parameters

Edit a Signal Source Window

On the **Video Wall Operation** page, select a video wall. Select a signal source window and perform the following operations as required:

- Adjust the window position: Move the window directly or enter the specific X and Y values.
- Divide the window: Click a window division icon.
- Adjust the window size:
 - Drag the window edge to adjust its size.
 - Enter W and H values.
 - Click  in the upper right corner of the window to make it fully cover the occupied output ports and click  to restore the original size.
- Set the window to the bottom: Click .

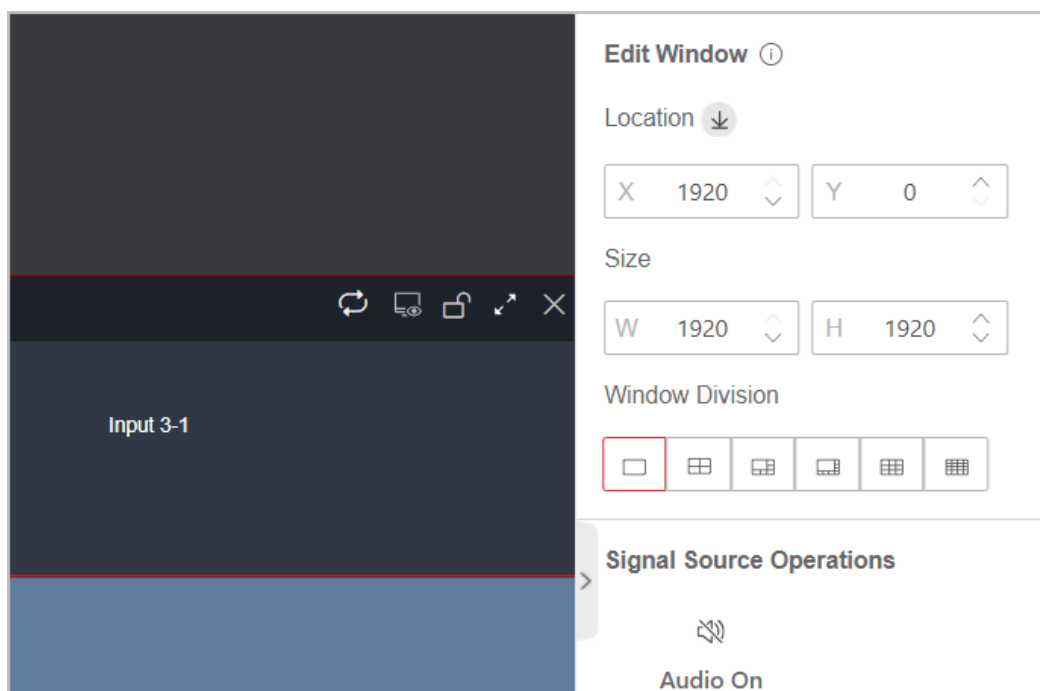

Figure 3-43 Adjust Position of a Signal Source Window

- Enable audio: Make sure that you have configured the audio output for the video wall on the **Video Wall Configuration** page. Click **Audio On**.
- Control a network signal source: Set the decoding delay level and export the stream. After you enable Websocket, you can export stream.

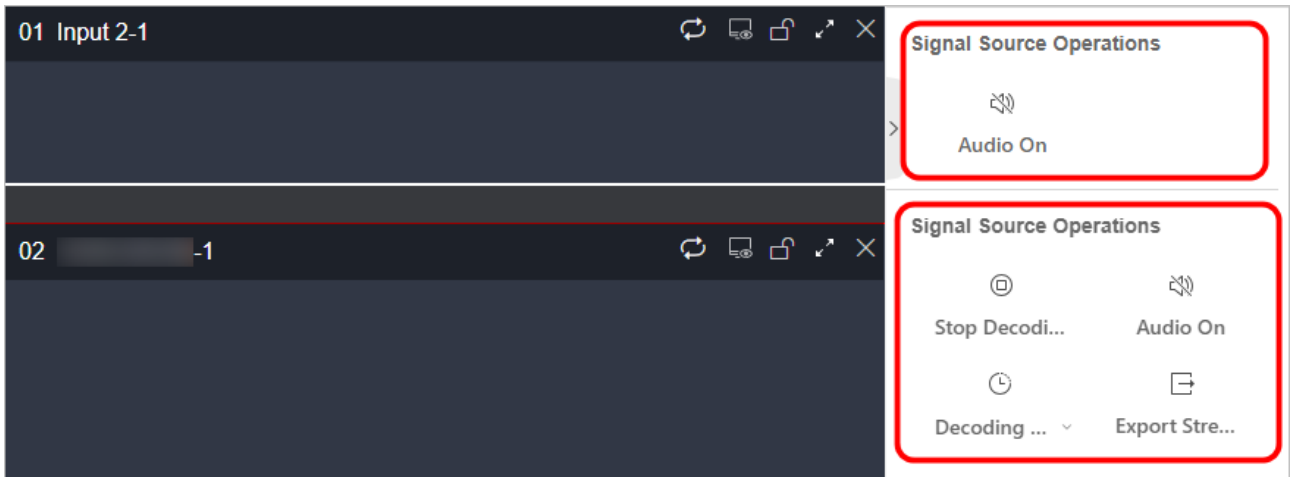



Figure 3-44 Enable Audio

- Set the signal source group auto-switching: Make sure that you have created signal source groups. For details, see Create a Signal Source Group. Click  in the upper right corner of the signal source window, select a signal source group, set the image interval, and then click **Start Auto-Switch**.

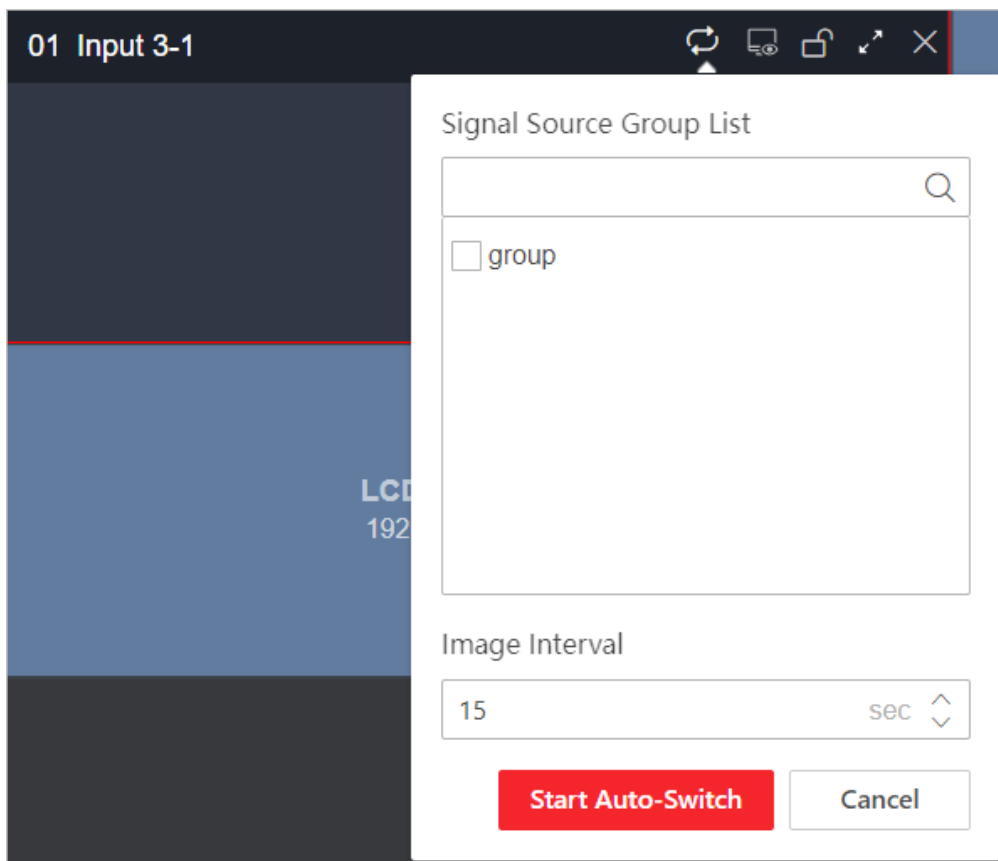

Figure 3-45 Set Signal Source Group Auto-Switching

- Lock the window: Click .

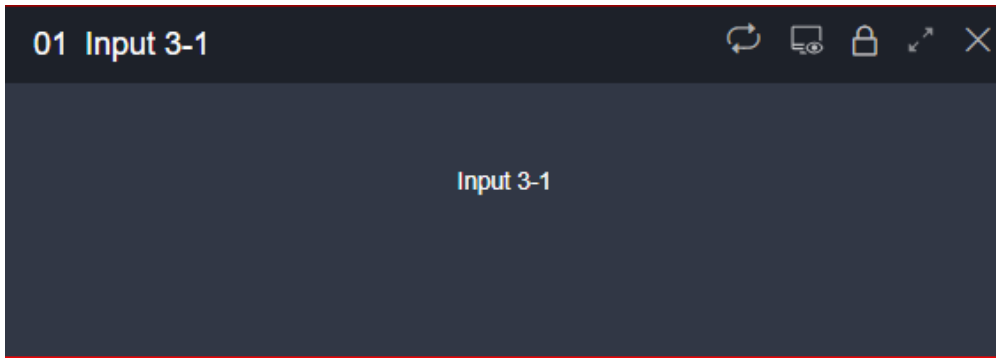



Figure 3-46 Locked Signal Source Window

- View the window status: You can click **Show All** to enter decoding status list to view details.

Edit Multiple Signal Source Windows

On the **Video Wall Operation** page, select a video wall and perform the following operations as required:

- Preview the signal sources:
 - Click  in the upper right corner of a signal source window to preview the signal source. Click  to cancel the live view.
 - Click **Enable Live View** at the top of the **Video Wall Operation** page to preview all signal sources on the video wall. Click **Close Live View** to stop previewing all signal sources on the video wall.
 - Click **Refresh Live View** at the top of the **Video Wall Operation** page to refresh the live view of all signal sources.

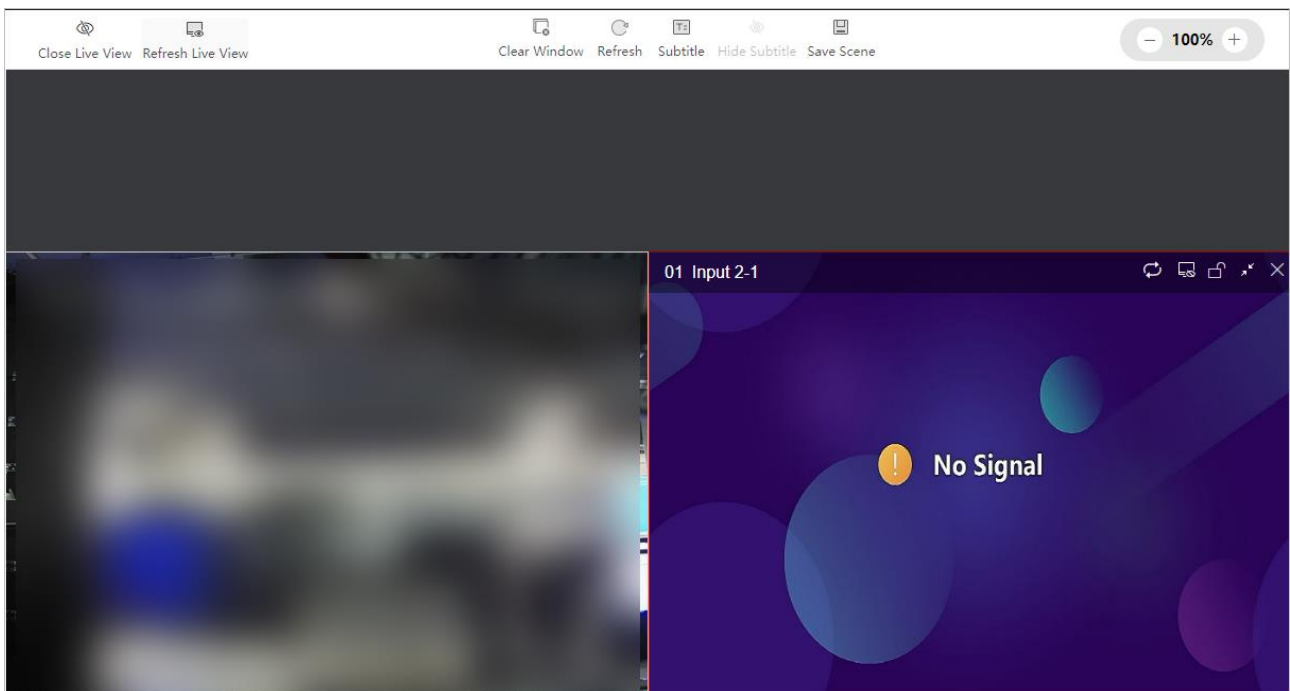

Figure 3-47 Preview Signal Source

- Clear all bound signal source windows: Click **Clear Window**.
- Power on all screens of the current video wall:
 - The LCD screens are powered on after you click **Screen On**.
 - The LED screens exit the sleep mode after you click **Screen On**.
- Power off all screens of the current video wall:
 - The LCD screens are powered off after you click **Screen Off**.
 - The LED screens enter the sleep mode after you click **Screen Off**.

3.3.2 Configure Subtitles

Go to **Video Wall Operation**, click **Subtitle**, press and hold the left mouse button to drag subtitles to the video wall. To add multiple subtitles, you can drag the remaining subtitles.

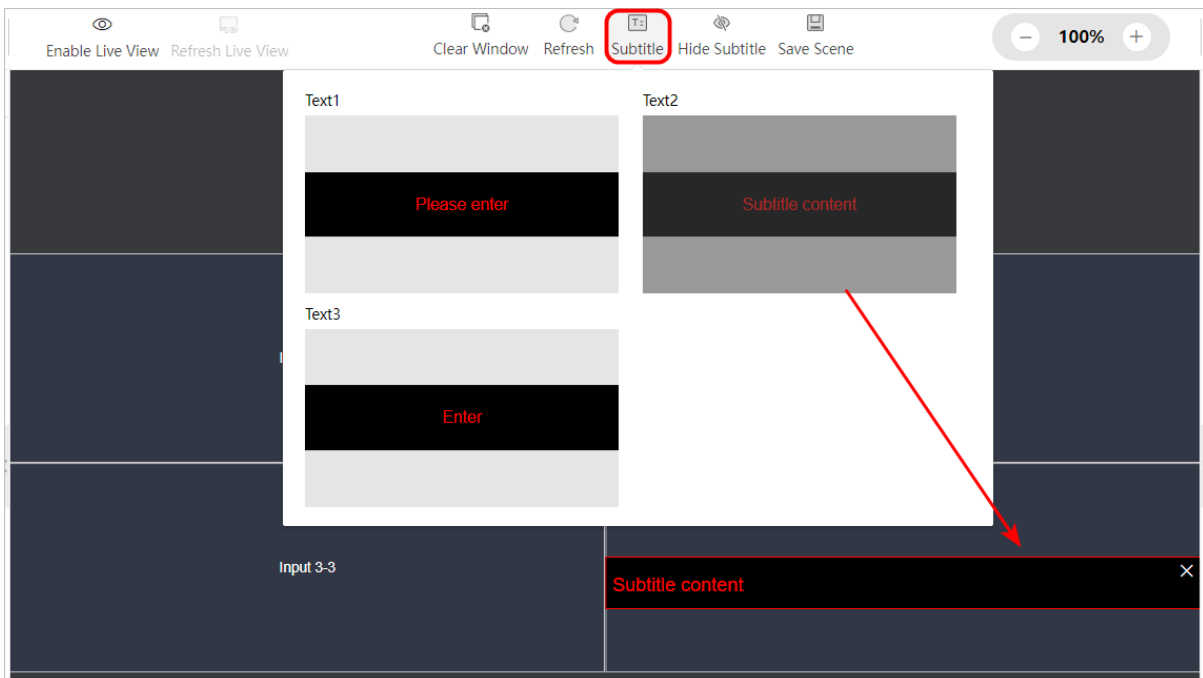

Figure 3-48 Add a Subtitle

- Add a text subtitle:
 - 1) Select **Text** for the subtitle type.
 - 2) Enter the subtitle content, adjust the subtitle position and size, and set the text and background.
 - 3) (Optional) Enable **Move** to set the movement speed.

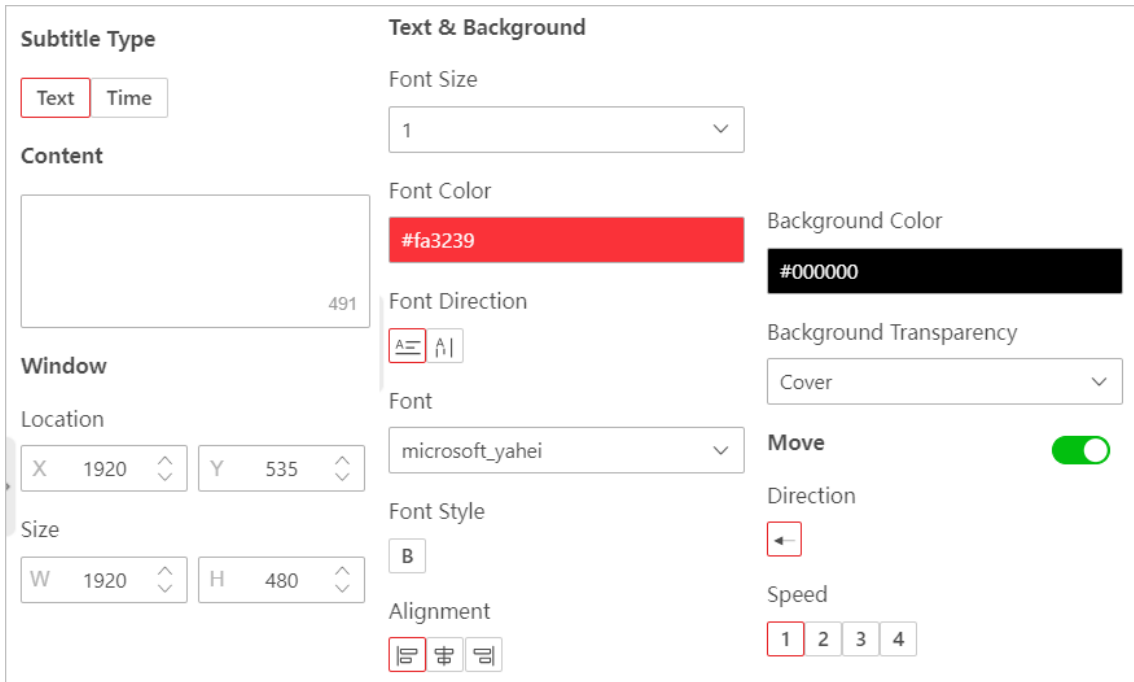

Figure 3-49 Add a Text Subtitle

- Add a time subtitle:
 - 1) Select **Time** as the subtitle type.
 - 2) Adjust the subtitle position and size, adjust the time format, and set the text and background.

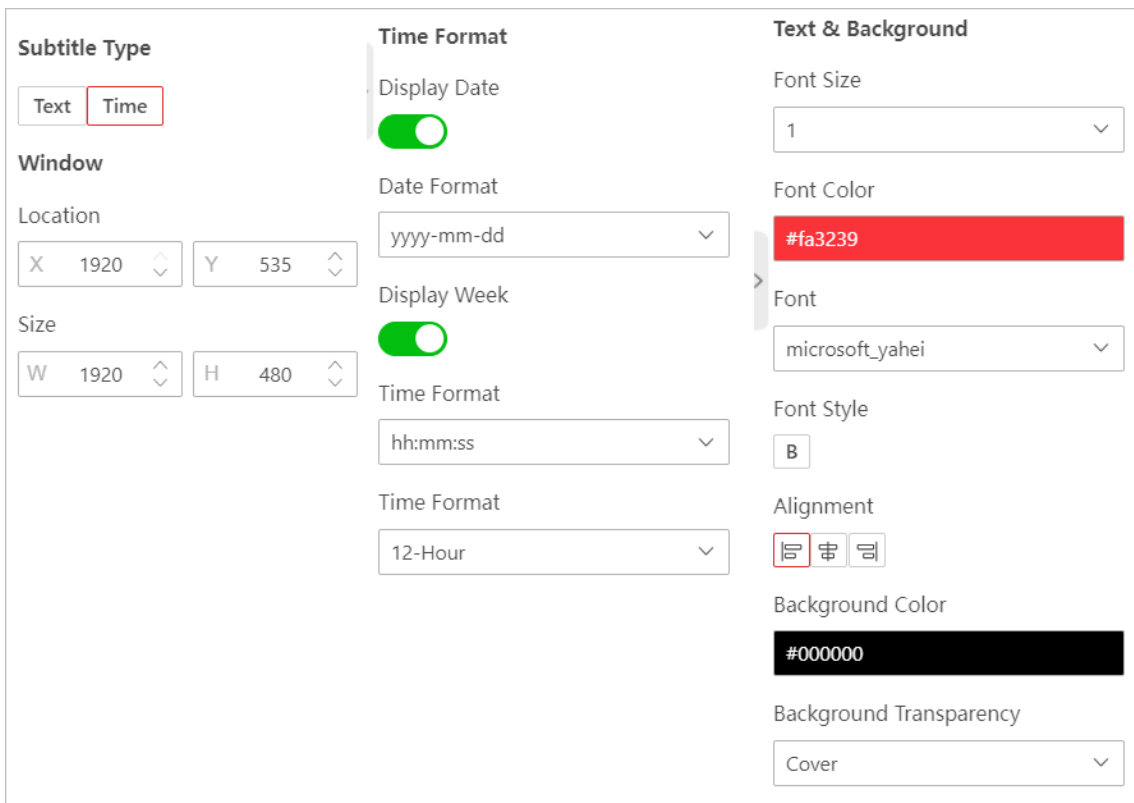

Figure 3-50 Add a Time Subtitle

3.3.3 Manage Scenes

Up to 128 scenes are supported. Go to **Video Wall Operation** to manage scenes.

- Click **Save Scene** to save the current video wall configuration as a new scene or overwrite the existing scene.

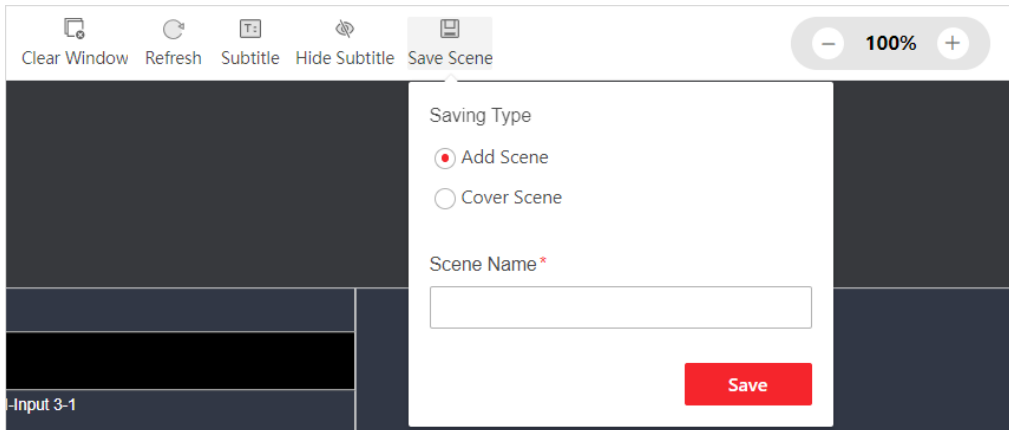





Figure 3-51 Save Scene

- Click **Scene** and hover over a scene name. Click  to call the scene.
- Click **Scene** and hover over a scene name. Click  to edit the scene name.
- Click **Scene** and hover over a scene name. Click  to delete the scene.

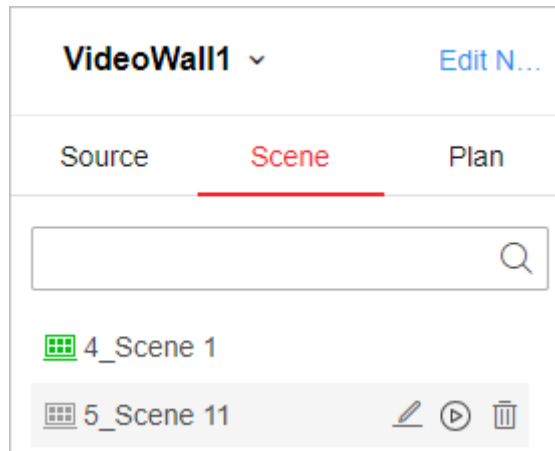

Figure 3-52 Manage Scene

3.3.4 Manage Plans

You can add multiple scenes and set the scene schedule in a plan. Go to **Video Wall Operation** and click **Plan** to manage plans.

- Click  to add a plan:
 - 1) Set the plan name.
 - 2) Add tasks.
 - 3) (Optional) Enable **Execute Plan Automatically** and set the schedule.

4) Click **Save**.

Add Plan [Close]

Plan Name *

Task

+ Add Task [Delete]

<input type="checkbox"/>	No.	Task	Scene Name	Interval(S)	Sort	Operation
<input type="checkbox"/>	1	Change Scene	scene 2	10	[Sort]	[Delete]

Execute Plan Automatically

Figure 3-53 Add a Plan

- Click a plan and then click to edit the plan.
- Click a plan and then click to call the plan.
- Click a plan and then click to delete the plan.

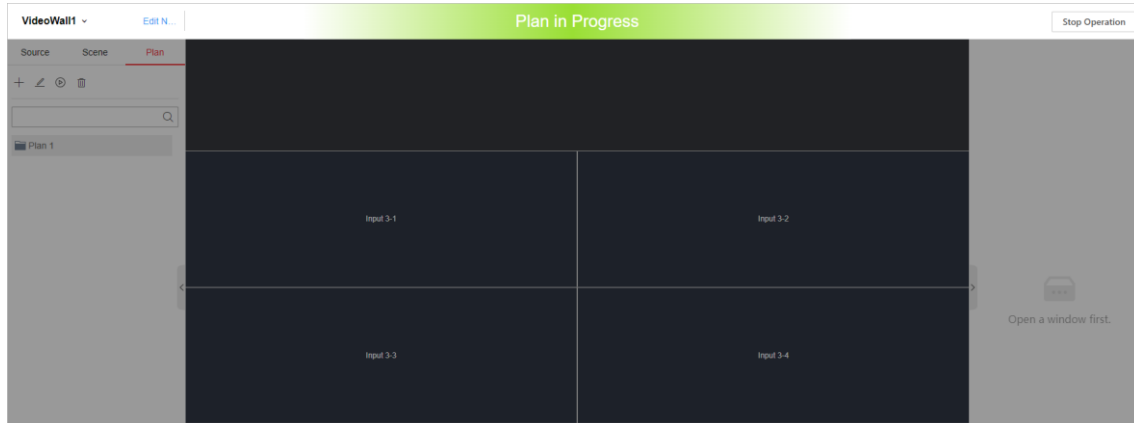

Figure 3-54 Call a Plan

3.3.5 Maintain Screens

Control Screen via Serial Port

Step 1 Go to **Configuration** → **System** → **Serial Port Settings** → **Main Node Serial Port**, select **Screen Control** as the working mode, set the baud rate of the device same as the baud rate of the screen, and set other serial port parameters.

The screenshot shows the 'Main Node Serial Port' configuration page. At the top, there are two buttons labeled '1' and '2' for selecting the serial port. Below that, the 'Serial Port Type' is set to 'RS232'. The 'Duplex Mode' is set to 'Full-Duplex'. The 'Baud Rate' is set to '115200'. The 'Data Bit' is set to '8'. The 'Stop Bit' is set to '1'. The 'Checking Type' is set to 'None'. The 'Flow Control Type' is set to 'None'. The 'Working Mode' is set to 'Screen Control'. The 'Serial Port Protocol' is set to 'RTSP'. A red 'Save' button is located at the bottom center of the form.

Figure 3-55 Configure Serial Port

 **Note**

- If you select **Keyboard Control** working mode, connect the keyboard to the device and set the baud rate of the device same as the baud rate of the keyboard.
- If you use a serial keyboard, click **Get/Refresh Signal Source** to obtain the local signal sources, and click **Add Signal Source** to add network signal sources. After you change the input board of the device, you need to click **Get/Refresh Signal Source** to refresh the local signal sources.

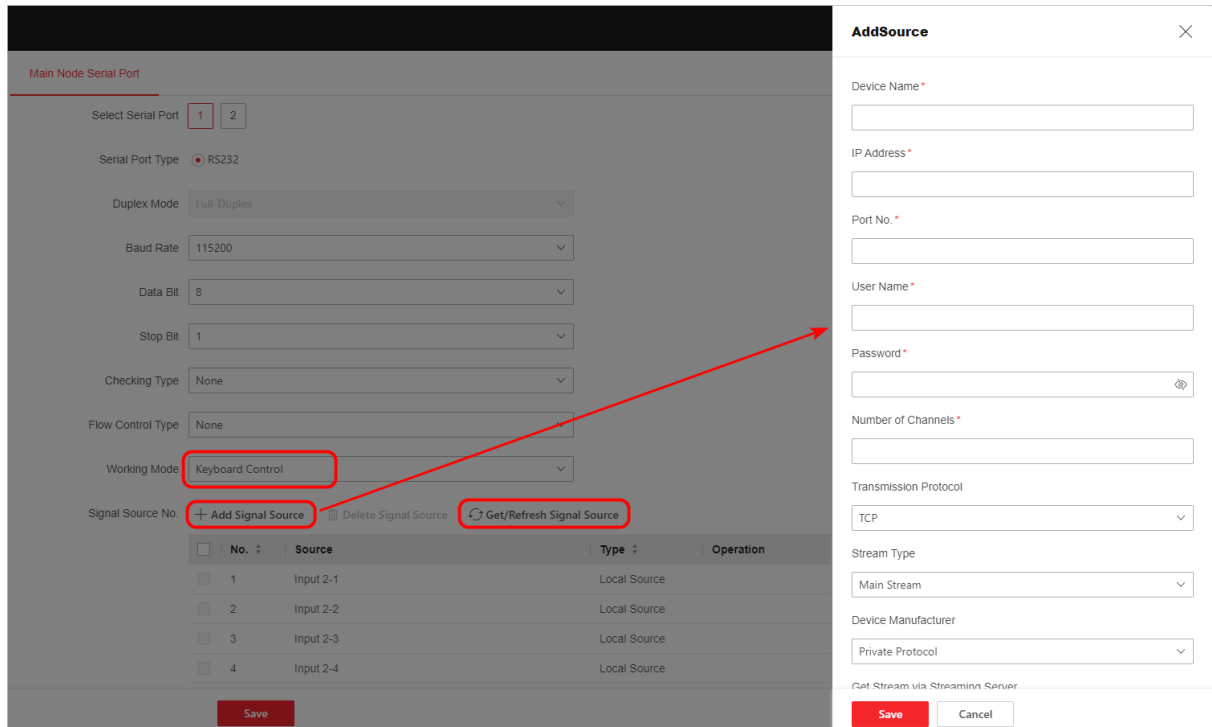

Figure 3-56 Control Serial Keyboard

Step 2 Use a serial port cable to connect a screen and the device RS-485 or RS-232 port.

Step 3 Go to **Screen Maintenance** and select the screen that is connected with the serial port cable.

Step 4 Select an input source type.

Step 5 Adjust the image position.

Step 6 (Optional) You can perform the following operations as required:

- Power on the connected screen through the serial port cable:
 - The LCD screen is powered on after you click **Screen On**.
 - The LED screen exits the sleep mode after you click **Screen On**.
- Power off the connected screen through the serial port cable:
 - The LCD screen is powered off after you click **Screen Off**.
 - The LED screen enters the sleep mode after you click **Screen Off**.

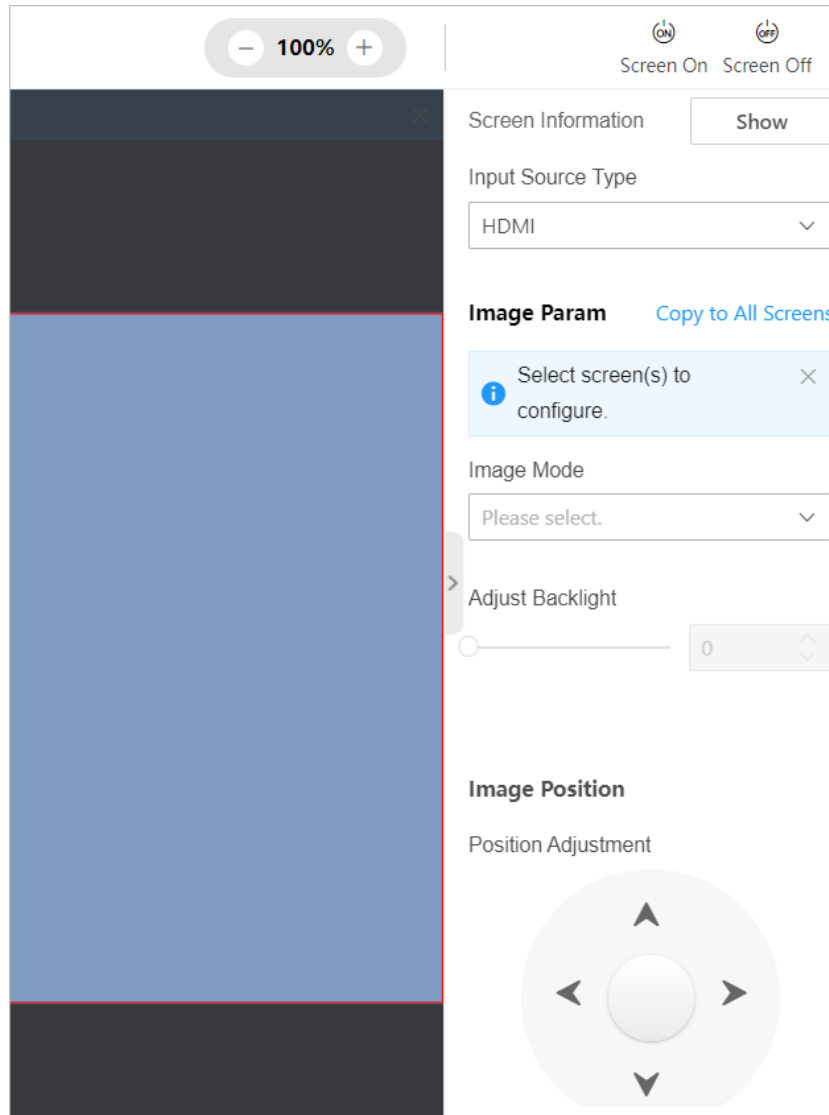

Figure 3-57 Control Screen via Serial Port

Control Screens via HDMI Ports

Step 1 Use multiple HDMI cables to connect the multiple screens to the device. Make sure all connected screens support and are enabled with the control linkage function.

Step 2 Go to **Screen Maintenance** and select a screen.

Step 3 Select an image mode and adjust the backlight.

Step 4 (Optional) You can perform the following operations as required:

- Click **Show** to show the serial number, software version, work duration and device temperature on all screens.
- Power on the connected screens through the HDMI cables:
 - The LCD screens are powered on after you click **Screen On**.
 - The LED screens exit the sleep mode after you click **Screen On**.

- Power off the connected screens through the HDMI cables:
 - The LCD screens are powered off after you click **Screen Off**.
 - The LED screens enter the sleep mode after you click **Screen Off**.
- Click **Copy to All Screens** to copy the image parameters of the current screen to all screens.

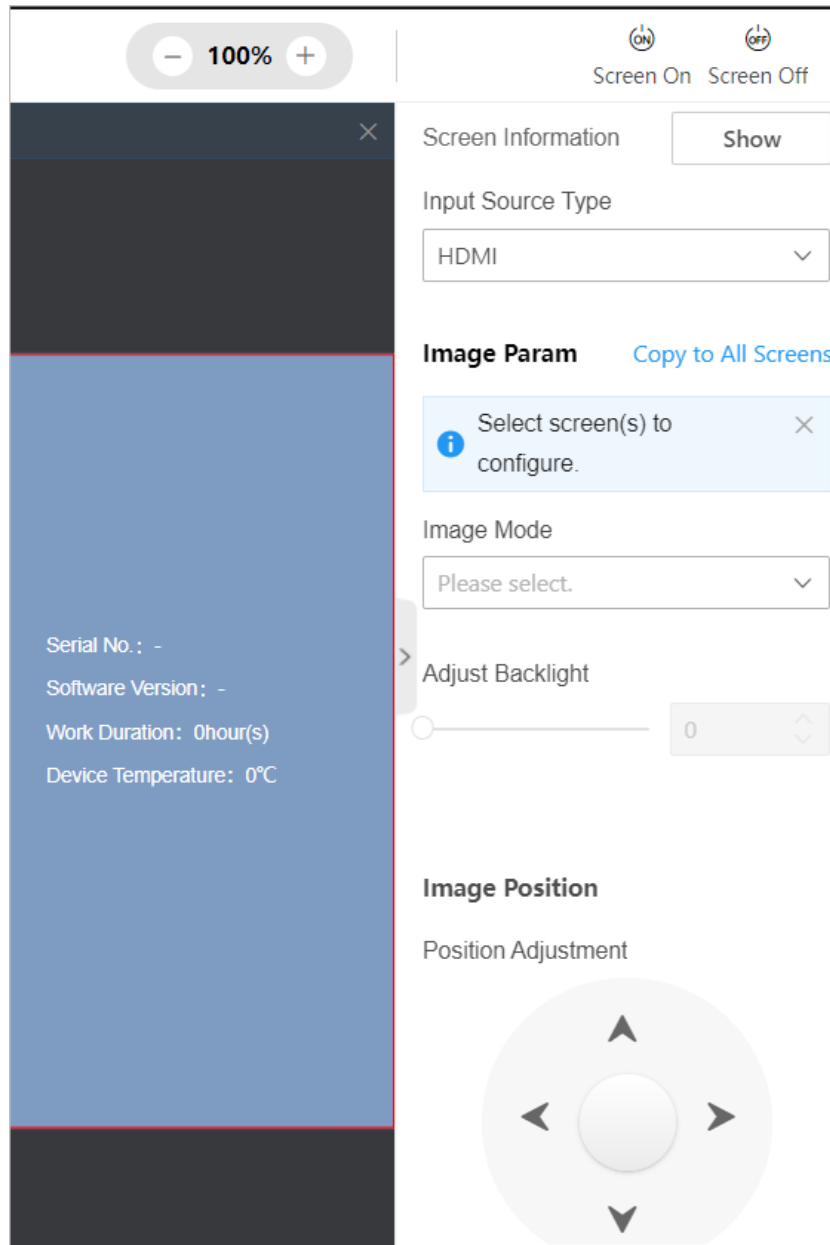



Figure 3-58 Show Screen Information

3.4 Configure Image Effect on Screen

3.4.1 Edit a Signal Source

Edit a Local Signal Source

Go to **Video Wall Operation**, hover over a local signal source and then click  to edit its parameters:

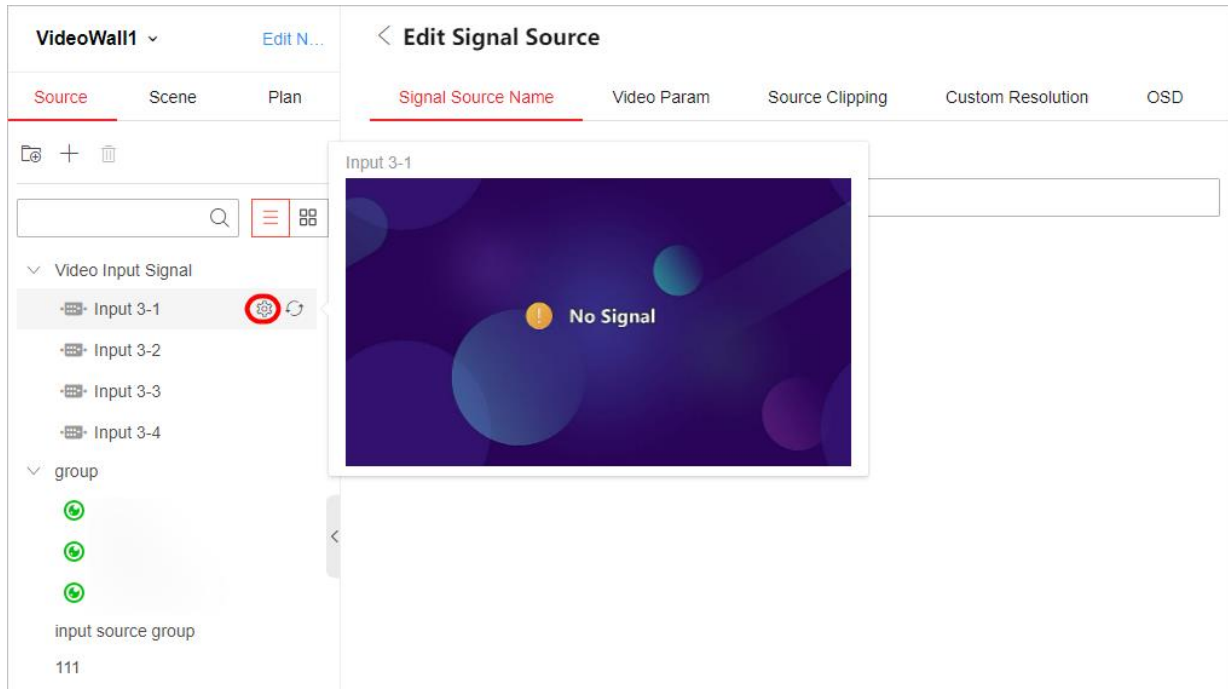

Figure 3-59 Edit a Local Signal Source

- Edit the signal source name.
- Click **Video Param**, select a color mode, and adjust the brightness.

If you select custom color mode, the video parameters will restore to the default settings after you click **Restore Default** on the **Backup and Reset** page.

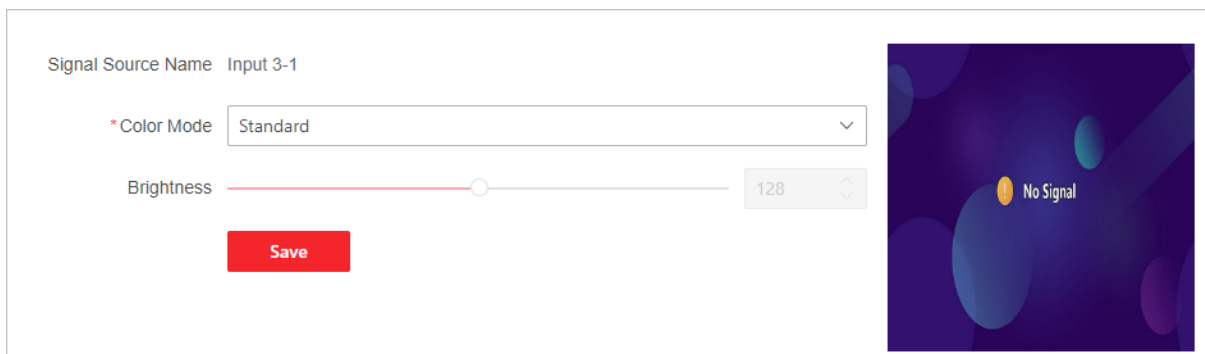

Figure 3-60 Set Video Parameters

- Click **Source Clipping**, and set the clipping value at top, bottom, left, and right edges.

The clipping value ranges from 0 to 200. The clipping value at the top and bottom edges should be a multiple of 2, and the clipping value at the left and right edges should be a multiple of 4.

Figure 3-61 Clip a Signal Source

- If the resolution of a signal source does not match the resolution of the screen, you can customize the signal source resolution.
 - 1) Click **Custom Resolution**.
 - 2) Enable custom resolution and set the refresh rate and resolution. The width should be a multiple of 4 and the height should be a multiple of 2.
 - 3) (Optional) Click **Copy To** to copy the resolution configuration of the current signal source to other signal sources.
 - 4) Click **Save**.

Figure 3-62 Customize Resolution

- Click **OSD**, and then you can add multiple OSDs (On-Screen Displays) to the input signal image.
 - Overlay the character 1 to the input signal image. Set the content, font size, and font color, and adjust the character position. You can enter the position values or directly drag the character to adjust the position.

- Overlay the character 2 to the input signal image. Set the content, font size, and font color, and adjust the character position. You can enter the position values or directly drag the character to adjust the position.
- Click **Copy To** to copy the OSD configuration of the current signal source to other signal sources.

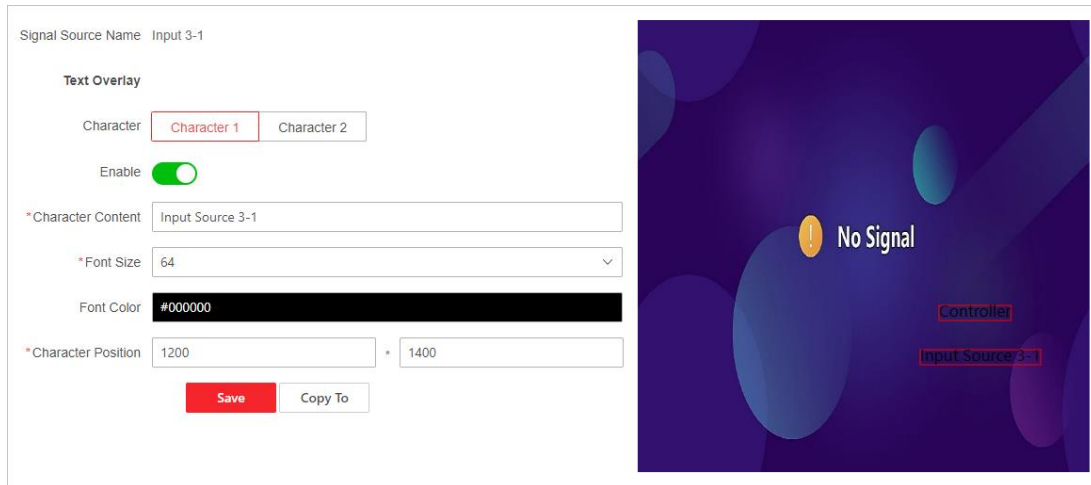

Figure 3-63 Add OSDs

Edit a Network Signal Source

Go to **Video Wall Operation**, hover over a network signal source and then click  to edit its parameters.

Figure 3-64 Edit a Network Signal Source

3.4.2 Splice Signal Source

This function allows you to splice multiple signal source images into one signal source image. After the signal source splicing, the spliced signal sources will disappear from the signal source list.

Note

- Only UHD signal sources (such as 4K HDMI input channels or 4K DP input channels) support splicing.
- All spliced signal sources should use the same resolution and frame rate to avoid affecting the display effect.
- The joint signal source will be displayed in one signal source window on the video wall.
- When the joint signal source window is floating or zooming on the video wall, the spliced signal source windows also float and zoom on the video wall.

Step 1 Go to **Configuration** → **Signal Source Splicing**, click .

Step 2 Customize the joint signal source name and splicing scale.

Step 3 Drag the signal source in the signal source list to the splicing window.

The signal sources that are dragged to the splicing window will be spliced to one-way signal source.

Step 4 (Optional) Click **Cancel All Linkage** to cancel the previous signal source splicing and splice the signal sources again.

Step 5 Click **Save**.

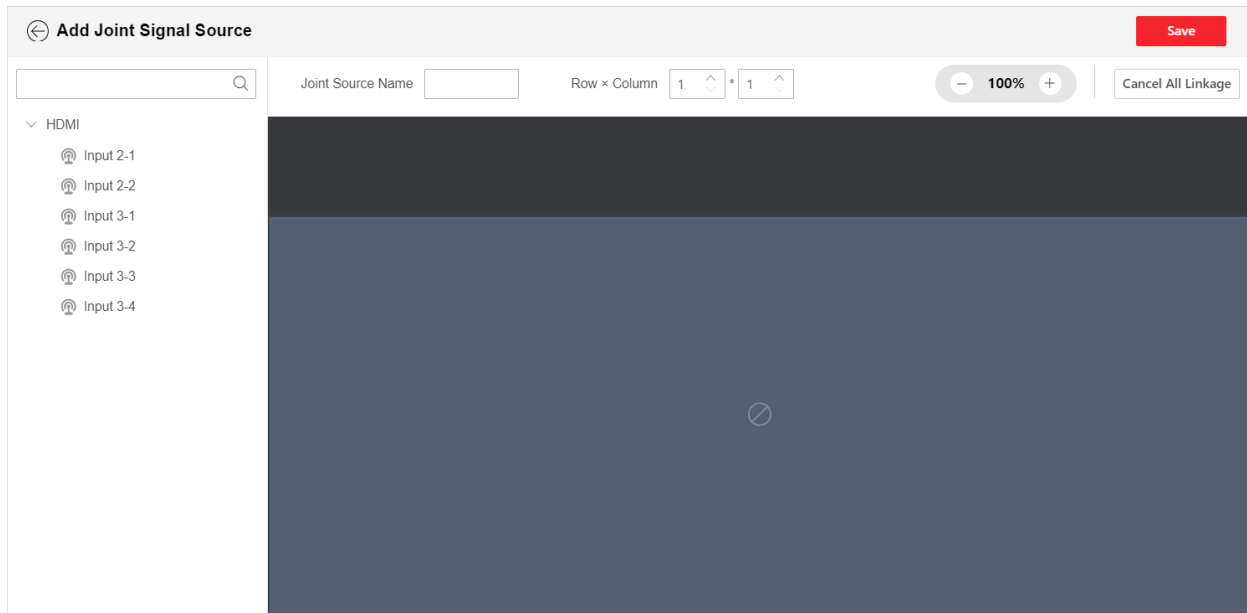

Figure 3-65 Add a Joint Signal Source

3.4.3 Set Other Parameters of Device

Go to **Configuration** → **Other Settings** to set the following parameters:

- Enable **Sub-Stream Auto-Switch** and set the window division threshold.

If the window division reaches the window division threshold, the device will automatically use sub-stream to get the images. In low bandwidth networks, you can use sub-stream to get relatively smooth images with a small bandwidth footprint.

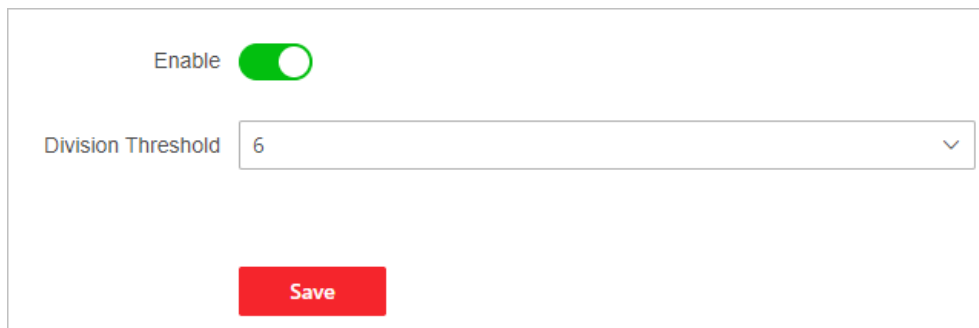
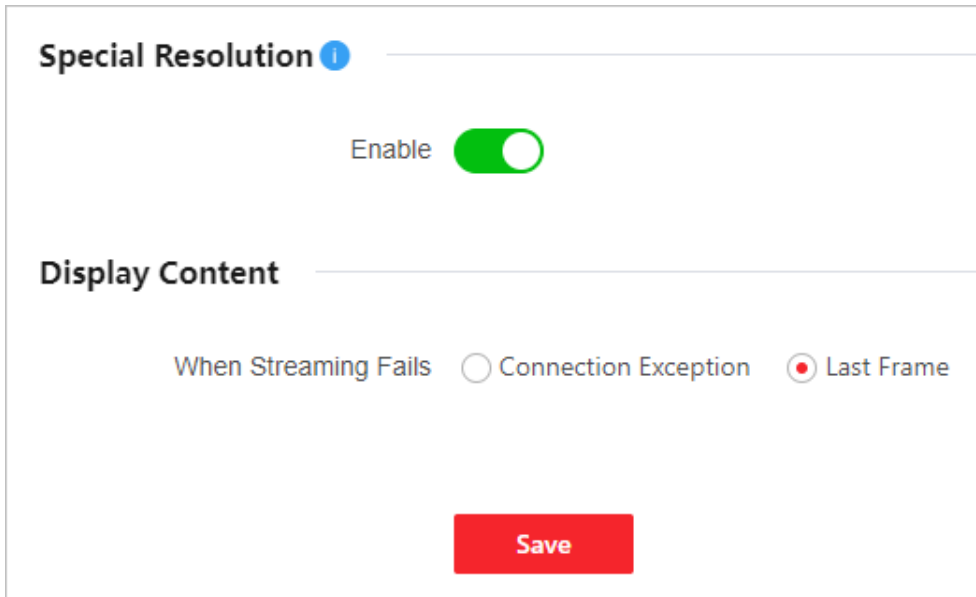

Figure 3-66 Set Sub-Stream Auto-Switch

- Click **Display Settings** to enable special resolution or configure the content displayed when streaming fails.
 - To set an LED video wall that uses varied height of the same row or varied width of the same column, enable the special resolution and set the special resolution on the **Video Wall Configuration** page.
 - If you select **Connection Exception**, the specific streaming failure reason will be shown on the screen.



The screenshot shows a configuration panel with two main sections. The top section is titled 'Special Resolution' with an information icon. Below it is a toggle switch labeled 'Enable' which is currently turned on (green). The bottom section is titled 'Display Content' and contains three radio button options: 'When Streaming Fails', 'Connection Exception', and 'Last Frame'. The 'Last Frame' option is selected. A red 'Save' button is located at the bottom center of the panel.

Figure 3-67 Set Display Content

- Click **Scene Change** to enable **Change Subtitle as Scene Changes**.
- Click **Decoding Delay** and select a default decoding delay level.
- When the preview board is in the device, you can display the image of a video wall on the connected screen(s). Click **Display a Video Wall Image on Screen**, select a video wall and then enable this function.

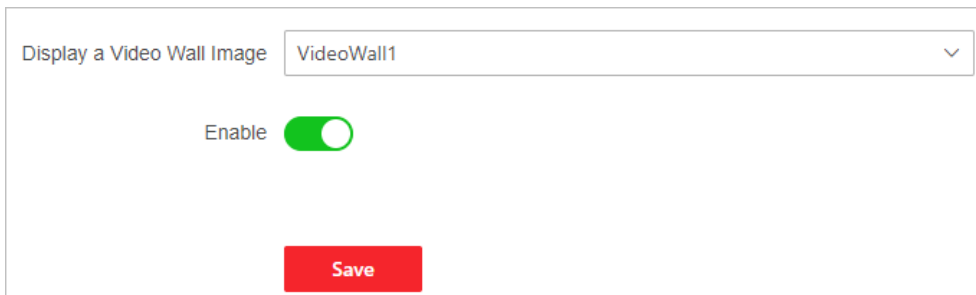

The screenshot shows a configuration panel for 'Display a Video Wall Image on Screen'. It features a dropdown menu with 'VideoWall1' selected. Below the dropdown is a toggle switch labeled 'Enable' which is currently turned on (green). A red 'Save' button is located at the bottom center of the panel.

Figure 3-68 Display a Video Wall Image on Screen

- Configure sub-board mode:
When the DS-D60S-02HO/4K sub-board is inserted into the device, you can configure the sub-board mode.

- If you select **Copy Mode**, the output port 2 will copy the image of the output port 1, only the output port 1 can be bound with the video wall, and the maximum resolution is 4K 60 fps.
- If you select **Independent Mode**, the output port 1 and output port 2 can be bound with the video wall and the maximum resolution of each port is 4K 30 fps.

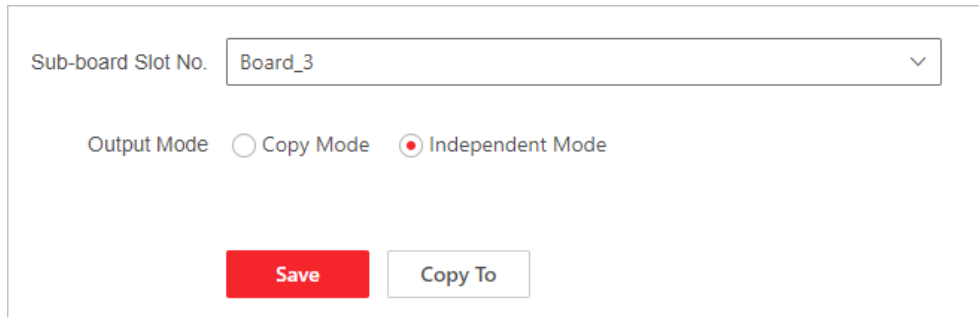

Sub-board Slot No. Board_3

Output Mode Copy Mode Independent Mode

Save Copy To

Figure 3-69 Configure Sub-board Mode

- Click **No Signal Image** to use the default image or upload a new image.

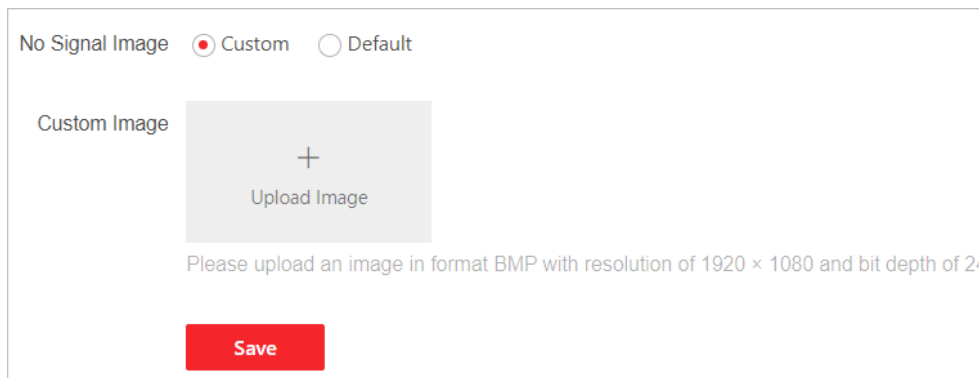

No Signal Image Custom Default

Custom Image

Please upload an image in format BMP with resolution of 1920 x 1080 and bit depth of 24

Save

Figure 3-70 Configure No Signal Image

Chapter 4 Device Maintenance

4.1 View Device Status

Go to **Overview** to view the device status. You can click a board to view its basic information and its usage.

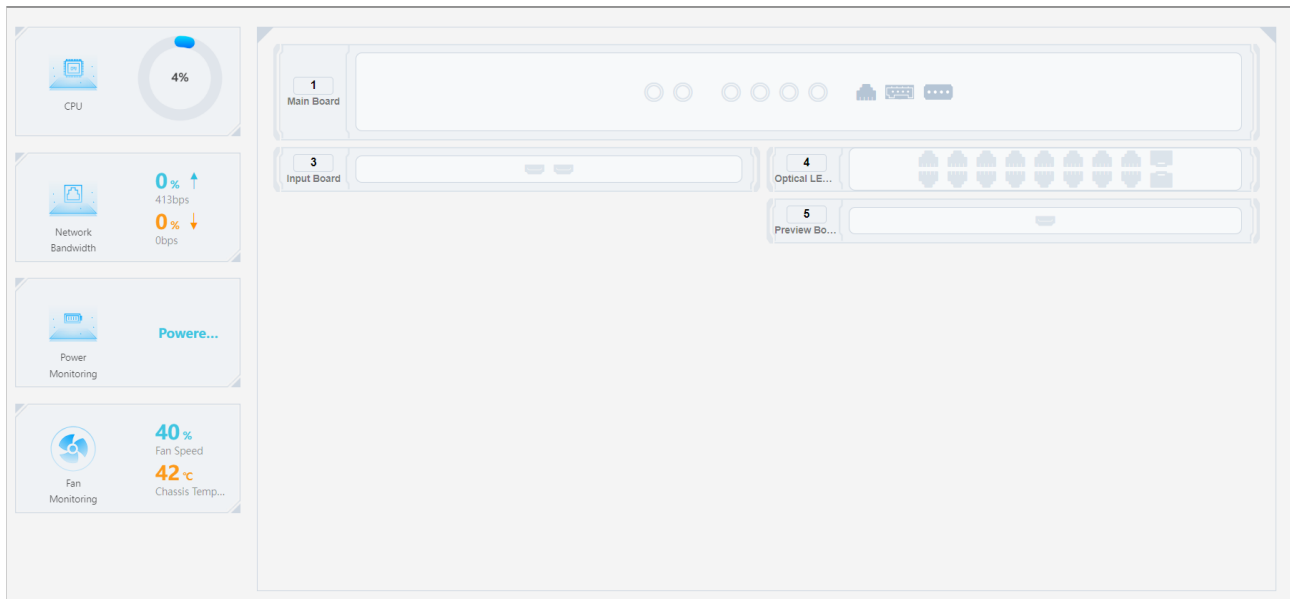

Figure 4-1 View Device Status

4.2 Configure System Parameters

Go to **Configuration** → **System** to configure the following parameters:

- Go to **System Settings** → **Basic Information** to view the device information and edit the device name as required. You can click **Upgrade** to go to the **Upgrade** page.

Figure 4-2 View Basic Information

- Go to **System Settings** → **Time Settings**, if you select **NTP Sync**, the device time synchronizes with the time of the NTP server at the specified interval.
 - Set the address and port number of the NTP server.
 - Set the synchronization interval.

Figure 4-3 Select NTP Sync

- On the **Time Settings** page, if you select **Manual Time Sync**, you can click **Sync with Computer** to make the device time same as the computer time.

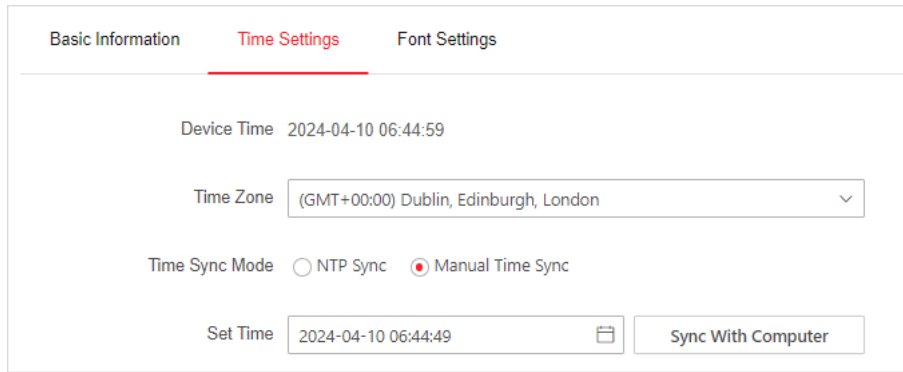

Figure 4-4 Select Manual Time Sync

- On the **Time Settings** page, if you enable DST (Daylight Saving Time), the device time is set forward a specified time during the summer months.

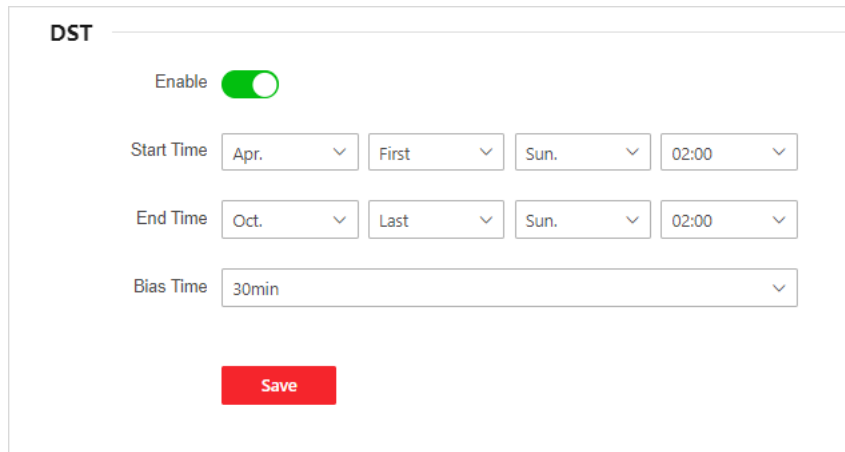

Figure 4-5 Enable DST

- Go to **System Settings** → **Font Settings** to set the font of OSDs and subtitles.
 - Use the default font.
 - Click **Add** to import a new font and enable the new font.

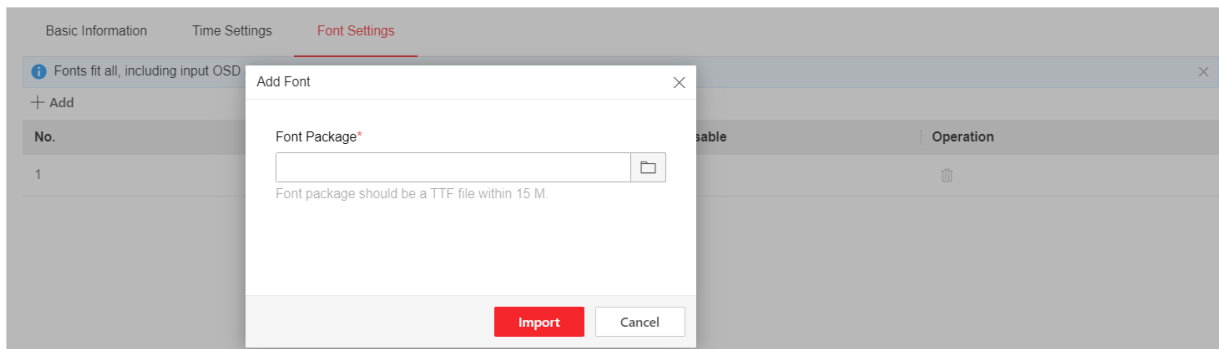

Figure 4-6 Set Font

- Go to **User Management** → **User Management** to add users, edit the user name or password, or delete the users.

You cannot edit the user name or password of the admin user or delete the admin user.

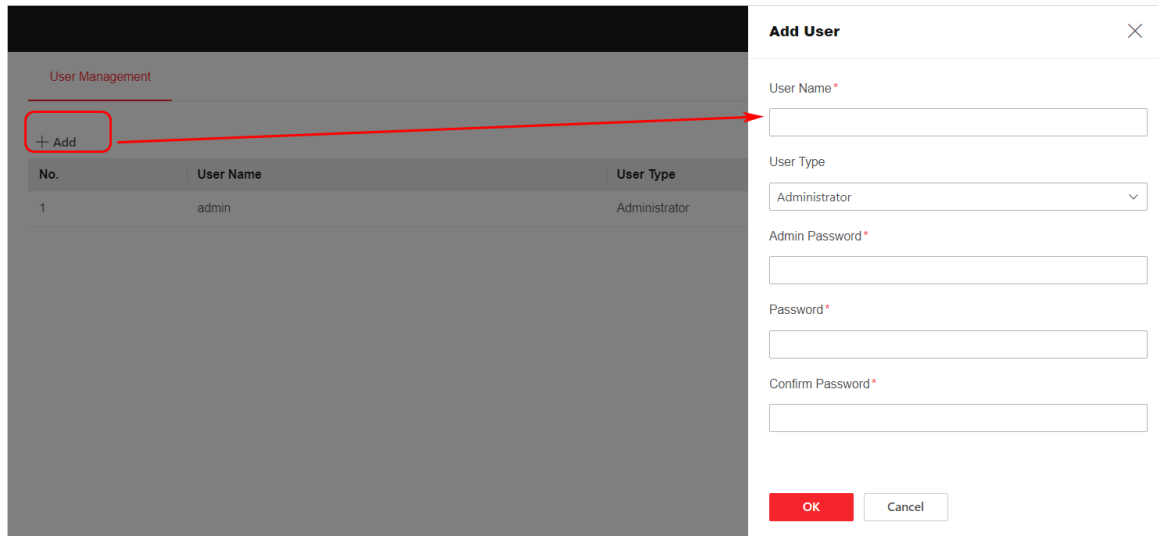

Figure 4-7 Manage Users

4.3 Configure HTTP(S) Parameters

Step 1 Go to **Configuration** → **Network** → **Network Service** → **HTTP(S)**.

Step 2 Set the HTTP port number.

The port number can be either 80 or any value from 2000 to 65535. After editing the HTTP port, you need to enter HTTP://Device IP Address: Port in the browser to access the device.

Step 3 Enable HTTPS and then set the HTTPS port.

The default port number is 443. After editing the HTTPS port, you need to enter HTTPS://Device IP Address: Port in the browser to access the device.

Step 4 (Optional) Enable auto HTTPS redirection to access the device via HTTPS by default.

Step 5 Select an authentication mode and digest algorithm type.

Step 6 Click **Save**.

HTTP(S)

HTTP

* HTTP Port

HTTPS

Enable

* HTTPS Port

Redirect to HTTPS Automatically

HTTP(S) Authentication

* Authentication Mode

* Digest Algorithm Type

Save

Figure 4-8 Configure HTTP (S) Parameters

4.4 Configure Events

Go to **Configuration** → **Event** to configure the audible warning and alarm reporting to the platform when the following exceptional events occur:

- The IP address of the device is the same as that of other devices in the network.
- Incorrect user name or password.
- Network is disconnected.
- The device temperature is too high or too low.
- The fan status is abnormal.

Device Exception Alarm

IP Address Conflict Trigger Audible Warning Report to the Platform

Invalid Access Trigger Audible Warning Report to the Platform

Network Disconnected Trigger Audible Warning Report to the Platform

Temperature Alarm Trigger Audible Warning Report to the Platform

Fan Exception Trigger Audible Warning Report to the Platform

Save

Figure 4-9 Set Device Exception Alarm

4.5 Maintain the System

Go to **Maintenance and Security** → **System Maintenance** to configure the following parameters:

- On the **Restart** page, click **Restart**.
- On the **Upgrade** page, Click to select an upgrade file, and click **Upgrade**. You need to get the upgrade file in advance and save it locally.

i The upgrading process will take 1 to 10 minutes. Do not power off. The device will restart automatically after upgrading.

Current Version

Upgrade File

Figure 4-10 Upgrade the System

- On the **Backup and Reset** page, back up the device parameters.
- On the **Backup and Reset** page, reset the device:
 - Click **Restore Default** to restore the parameters except for user information and network parameters to the default settings. Please use this function with caution.
 - Click **Restore Factory** to restore all functions and parameters of the device to the factory settings. Please use this function with caution.
 - Click to select a parameter file saved locally, and click **Import** to import device parameters.

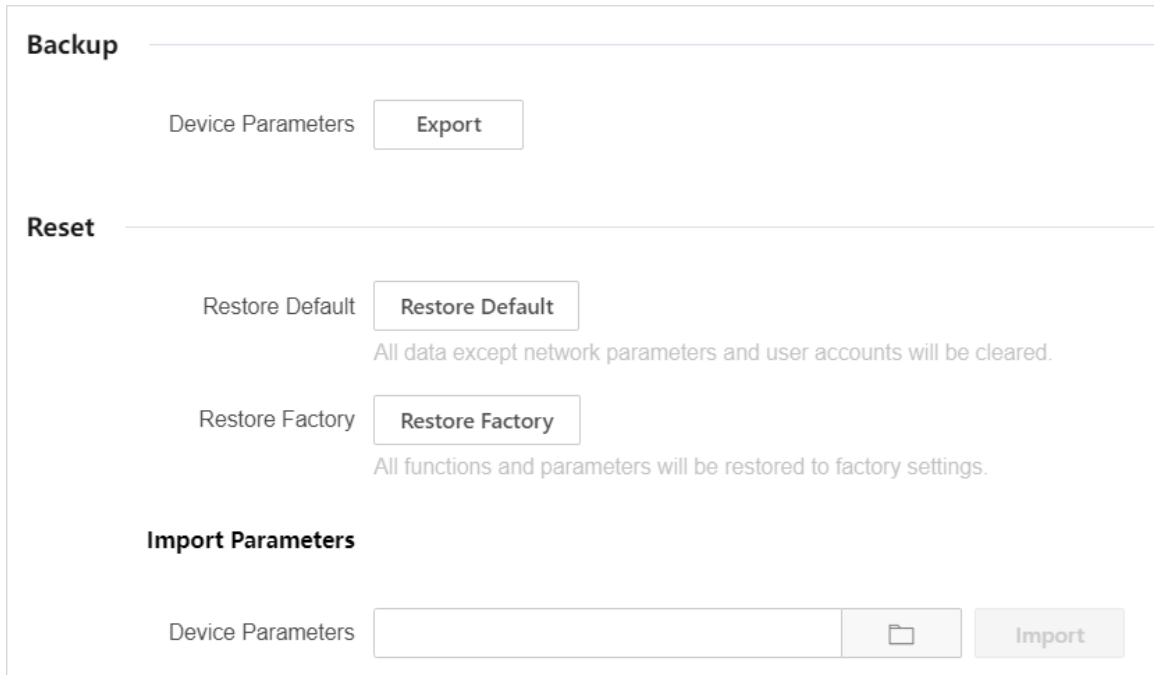

Figure 4-11 Backup and Reset Device Parameters

- On the **Log** page, set the search condition and click **Search**. You can view the searched logs in the list below and export the logs as required.

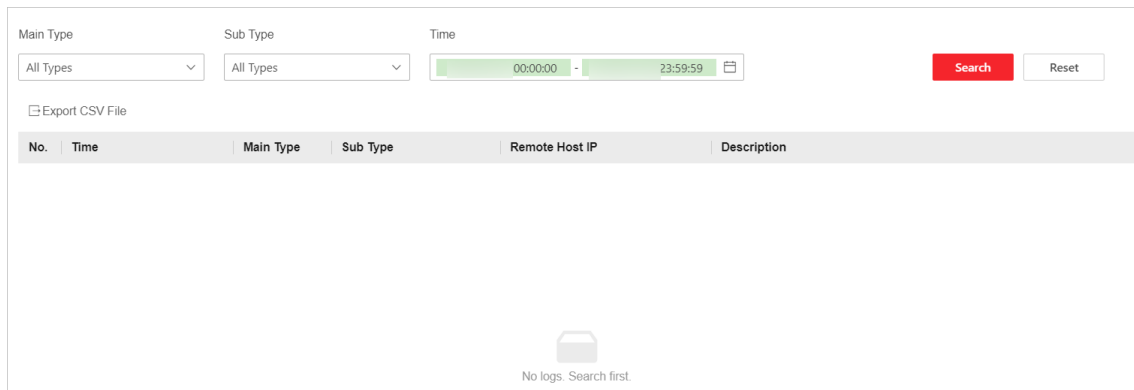

Figure 4-12 Search Logs

- On the **Device Debugging** page, configure the following parameters:
 - Enable SSH (Secure Shell) as required. With SSH enabled, you can use a computer installed with the SSH client to access the device.
 - Export the device information.
 - Select a sub-system, click **Start Capturing** and then you can download the obtained packet capture file.
 - Send a shell command and then check the response message.

The screenshot displays a web interface for SSH debugging, organized into four main sections:

- SSH:** Features an "Enable" toggle switch that is currently turned off.
- Export Device Info:** Includes a "Device Information" label and an "Export" button.
- Export Network Switching Packet:** Contains a "Subsystem" dropdown menu set to "Board0_SubSys0" and a "Start Capturing" button. Below this is a "Packet Capture File" area with a file icon and the text "Please click Start Capturing."
- Shell Command Operation:** Includes a "Shell Command" input field and a "Send" button. Below the input is a "Status" label and a "Response Message" area with a file icon and the text "Please send command first."

Figure 4-13 Debug the Device

4.6 Maintain the Device Security

Go to **Maintenance and Security** → **Security Management** to configure the following parameters:

- On the **IP Address Filter** page, configure the IP addresses that are allowed to or forbidden to access the device.

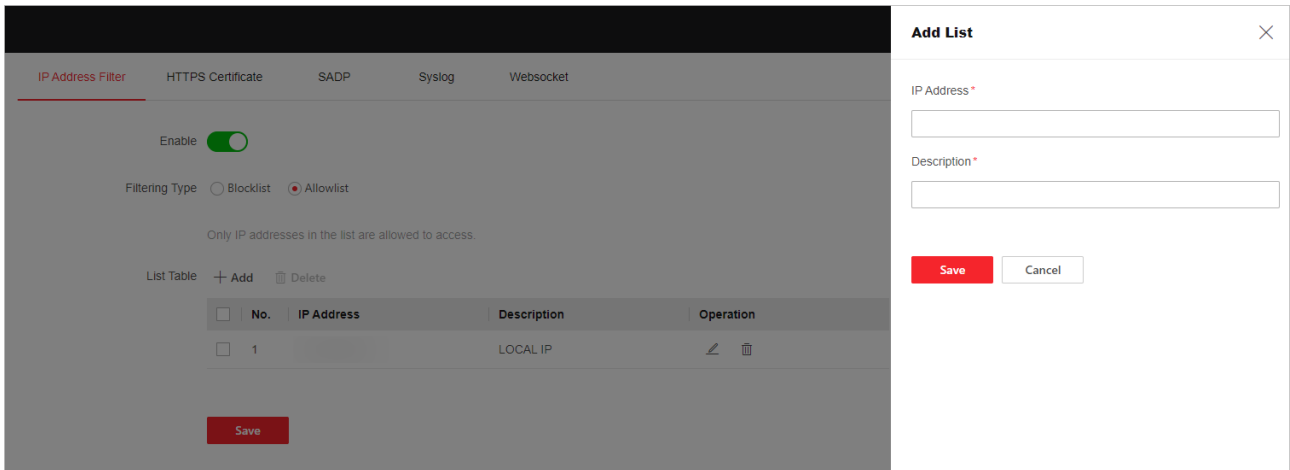

Figure 4-14 Configure IP Address Filter

- On the **HTTPS Certificate** page, import the locally saved HTTPS certificate and secret key.

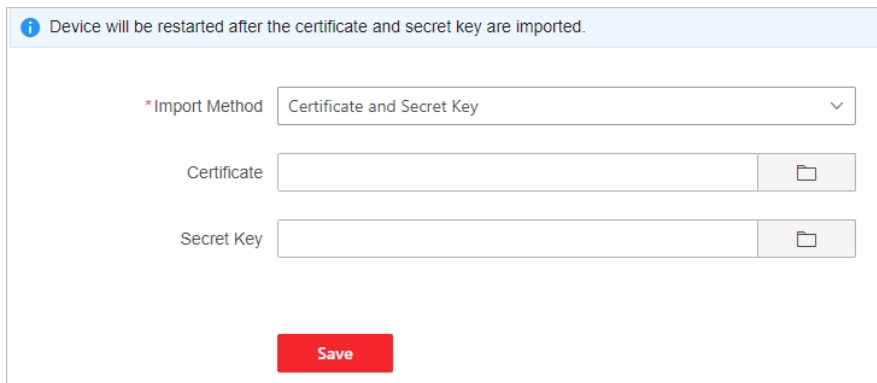

Figure 4-15 Import HTTPS Certificate and Secret Key

- On the **SADP** page, enable SADP as required. With SADP enabled, you can use the SADP software to search the online device that is in the same network segment with the computer.
- On the **Syslog** page, enable Syslog as required. With Syslog enabled, the device logs can be uploaded to the Syslog server.

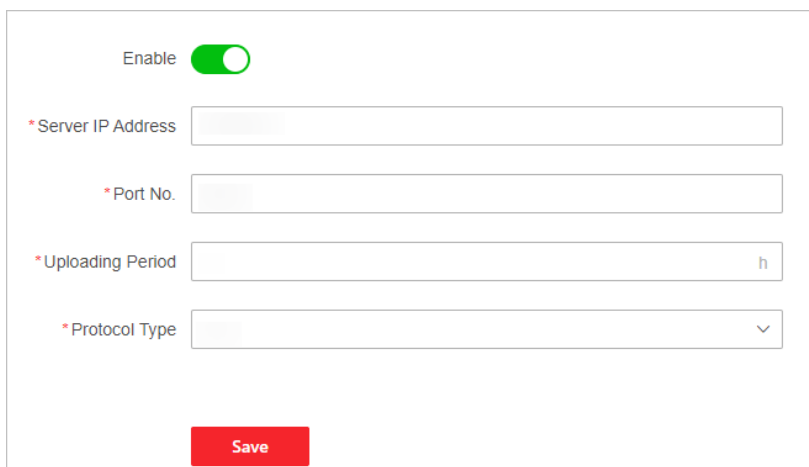
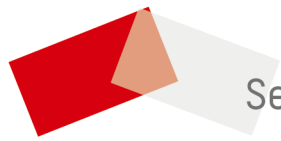

Figure 4-16 Enable Syslog

- On the **Websocket** page, enable Websocket as required. With Websocket enabled, you can export stream.



See Far, Go Further