



Distributed Video Wall Controller

Quick Start Guide

Legal Information

About this Document

- This Document includes instructions for using and managing the Product. Pictures, charts, images and all other information hereinafter are for description and explanation only.
- The information contained in the Document is subject to change, without notice, due to firmware updates or other reasons. Please find the latest version of the Document at the Hikvision website (<https://www.hikvision.com>). Unless otherwise agreed, Hangzhou Hikvision Digital Technology Co., Ltd. or its affiliates (hereinafter referred to as "Hikvision") makes no warranties, express or implied.
- Please use the Document with the guidance and assistance of professionals trained in supporting the Product.

About this Product

This product can only enjoy the after-sales service support in the country or region where the purchase is made.

Acknowledgment of Intellectual Property Rights

- Hikvision owns the copyrights and/or patents related to the technology embodied in the Products described in this Document, which may include licenses obtained from third parties.
- Any part of the Document, including text, pictures, graphics, etc., belongs to Hikvision. No part of this Document may be excerpted, copied, translated, or modified in whole or in part by any means without written permission.
- **HIKVISION** and other Hikvision's trademarks and logos are the properties of Hikvision in various jurisdictions.
- Other trademarks and logos mentioned are the properties of their respective owners.
- **HDMI**[™] The terms HDMI and HDMI High-Definition Multimedia Interface, and the HDMI Logo are trademarks or registered trademarks of HDMI Licensing Administrator, Inc. in the United States and other countries.

LEGAL DISCLAIMER

- TO THE MAXIMUM EXTENT PERMITTED BY APPLICABLE LAW, THIS DOCUMENT AND THE PRODUCT DESCRIBED, WITH ITS HARDWARE, SOFTWARE AND FIRMWARE, ARE PROVIDED "AS IS" AND "WITH ALL FAULTS AND ERRORS". HIKVISION MAKES NO WARRANTIES, EXPRESS OR IMPLIED, INCLUDING WITHOUT LIMITATION, MERCHANTABILITY, SATISFACTORY QUALITY, OR FITNESS FOR A PARTICULAR PURPOSE. THE USE OF THE PRODUCT BY YOU IS AT YOUR OWN RISK. IN NO EVENT WILL HIKVISION BE LIABLE TO YOU FOR ANY SPECIAL, CONSEQUENTIAL, INCIDENTAL, OR INDIRECT DAMAGES, INCLUDING, AMONG OTHERS, DAMAGES FOR LOSS OF BUSINESS PROFITS, BUSINESS INTERRUPTION, OR LOSS OF DATA, CORRUPTION OF SYSTEMS, OR LOSS OF DOCUMENTATION, WHETHER BASED ON BREACH OF CONTRACT, TORT (INCLUDING NEGLIGENCE), PRODUCT LIABILITY, OR OTHERWISE, IN CONNECTION WITH THE USE OF THE PRODUCT, EVEN IF HIKVISION HAS BEEN ADVISED OF THE POSSIBILITY OF SUCH DAMAGES OR LOSS.
- YOU ACKNOWLEDGE THAT THE NATURE OF THE INTERNET PROVIDES FOR INHERENT SECURITY RISKS, AND

HIKVISION SHALL NOT TAKE ANY RESPONSIBILITIES FOR ABNORMAL OPERATION, PRIVACY LEAKAGE OR OTHER DAMAGES RESULTING FROM CYBER-ATTACK, HACKER ATTACK, VIRUS INFECTION, OR OTHER INTERNET SECURITY RISKS; HOWEVER, HIKVISION WILL PROVIDE TIMELY TECHNICAL SUPPORT IF REQUIRED.

- YOU AGREE TO USE THIS PRODUCT IN COMPLIANCE WITH ALL APPLICABLE LAWS, AND YOU ARE SOLELY RESPONSIBLE FOR ENSURING THAT YOUR USE CONFORMS TO THE APPLICABLE LAW. ESPECIALLY, YOU ARE RESPONSIBLE, FOR USING THIS PRODUCT IN A MANNER THAT DOES NOT INFRINGE ON THE RIGHTS OF THIRD PARTIES, INCLUDING WITHOUT LIMITATION, RIGHTS OF PUBLICITY, INTELLECTUAL PROPERTY RIGHTS, OR DATA PROTECTION AND OTHER PRIVACY RIGHTS. YOU SHALL NOT USE THIS PRODUCT FOR ANY PROHIBITED END-USES, INCLUDING THE DEVELOPMENT OR PRODUCTION OF WEAPONS OF MASS DESTRUCTION, THE DEVELOPMENT OR PRODUCTION OF CHEMICAL OR BIOLOGICAL WEAPONS, ANY ACTIVITIES IN THE CONTEXT RELATED TO ANY NUCLEAR EXPLOSIVE OR UNSAFE NUCLEAR FUEL-CYCLE, OR IN SUPPORT OF HUMAN RIGHTS ABUSES.
- IN THE EVENT OF ANY CONFLICTS BETWEEN THIS DOCUMENT AND THE APPLICABLE LAW, THE LATTER PREVAILS.

© Hangzhou Hikvision Digital Technology Co., Ltd. All rights reserved.

Preface

Applicable Models

This manual is applicable to the DS-C80N distributed video wall controller.

Default Parameters



Type	Default Parameter
Device	• Login user name: admin
SSH connection	• IP address: 192.0.0.64

Caution

To improve system security, it is highly recommended to change password regularly. In order to protect your privacy and corporate data and avoid network security issues, it is recommended to set strong password that meets security requirements.

Symbol Conventions

The symbols that may be found in this document are defined as follows.

Symbol	Description
 Note	Provides additional information to emphasize or supplement important points of the main text.
 Caution	Indicates a potentially hazardous situation, which if not avoided, could result in equipment damage, data loss, performance degradation, or unexpected results.
 Danger	Indicates a hazard with a high level of risk, which if not avoided, will result in death or serious injury.

Safety Instructions



Caution

- The device must be connected to an earthed mains socket-outlet.
- The socket-outlet shall be installed near the device and shall be easily accessible.
- Do not touch the bare components (such as the metal contacts of the inlets) and wait for at least 5 minutes, since electricity may still exist after the device is powered off.
- Never place the device in an unstable location. The device may fall, causing serious personal injury or death.
- This device is not suitable for use in locations where children are likely to be present.



- **CAUTION:** Risk of explosion if the battery is replaced by an incorrect type.
- Improper replacement of the battery with an incorrect type may defeat a safeguard (for example, in the case of some lithium battery types).
- Do not dispose of the battery into fire or a hot oven, or mechanically crush or cut the battery, which may result in an explosion.
- Do not leave the battery in an extremely high temperature surrounding environment, which may result in an explosion or the leakage of flammable liquid or gas.
- Do not subject the battery to extremely low air pressure, which may result in an explosion or the leakage of flammable liquid or gas.
- Dispose of used batteries according to the instructions.
- Keep body parts away from fan blades. Disconnect the power source during servicing.



Note

- Make sure that the power has been disconnected before you wire, install, or disassemble the device.
- The device shall not be exposed to water dripping or splashing, and no objects filled with liquids, such as vases, shall be placed on the device.
- No naked flame sources, such as lighted candles, should be placed on the device.
- If smoke, odor, or noise arises from the device, immediately turn off the power, unplug the power cable, and contact the service center.
- Install the device according to the instructions in Quick Start Guide.
- To prevent injury, this device must be securely attached to the installation surface in accordance with the installation instructions.
- The ventilation should not be impeded by covering the ventilation openings with items, such as newspapers, table-cloths, curtains. The openings shall never be blocked by placing the device on a bed, sofa, rug, or other similar surface.

TABLE OF CONTENTS

Chapter 1 Introduction	1
1.1 Overview	1
1.2 Appearance.....	1
1.2.1 Front Panel.....	1
1.2.2 Rear Panel	2
Chapter 2 Installation	5
2.1 Installation Process	5
2.2 Open Package and Check Items	5
2.3 Safety Precautions	5
2.4 Power On and Activate Nodes	7
2.4.1 Connect the Power Cords	7
2.4.2 Batch Activate Nodes.....	7
2.5 Configure the Cluster	9
2.5.1 Check the Streaming Mode.....	9
2.5.2 Select a Switch Type.....	10
2.5.3 Connect Nodes to Switches	10
2.5.4 Connect the Computer to a Switch.....	13
2.5.5 Configure the Command Lines.....	15
2.6 Install the Nodes	19
2.6.1 Rack Installation	20
2.6.2 Magnetic Installation	24
2.7 Connect the Grounding Cable for Each Node	25
Chapter 3 Get More Information	28

Chapter 1 Introduction

1.1 Overview

The distributed video wall controller (hereinafter referred as the device) uses distributed deployment mode, which consists of multiple input nodes and output nodes, realizing the collection and access, transmission and exchange, analysis and processing, and scheduling presentation of video and audio signals. Each node in the architecture has independent data processing and computing capabilities. Compared with the traditional central control equipment, the device scale is more elastic and the device has better stability and robustness because the failure of a single node does not affect the normal operation of other nodes. As a professional audio-visual control product, the device can be widely used in the command centers, exhibition halls, lecture halls, conference rooms, and other places involving audio-visual applications and management scheduling.

The device adopts dual-engine technology, which can not only realize the lossless decoding of signals to meet the local users' needs for high-quality signals, but also through the signal encoding and compression to realize the signal transmission on the WAN to meet the user's needs for remote signal scheduling.

1.2 Appearance

1.2.1 Front Panel

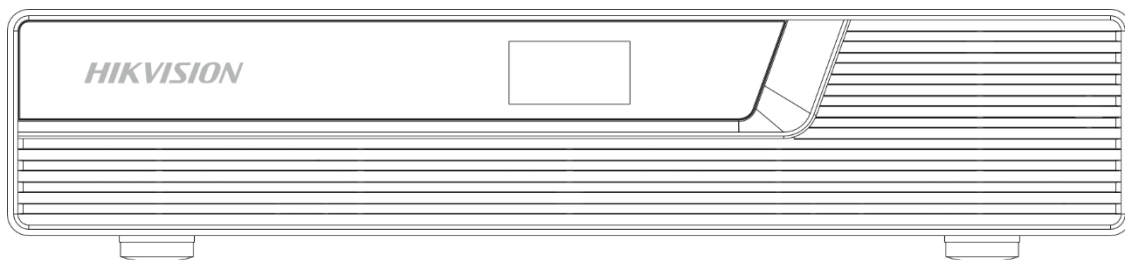

Figure 1-1 Front Panel

The front panels of all input and output nodes are the same.

The display on the front panel will show node information, including version, IP address and port No. of the node, IP address of the main control node, current time, slot No., login status, temperature, and IP conflict status.

Front panel indicator and status are as follows.

- Steady red: the node is starting.
- Steady blue: the node is running normally.
- Flashing blue: the node is positioning.

1.2.2 Rear Panel

Input Node

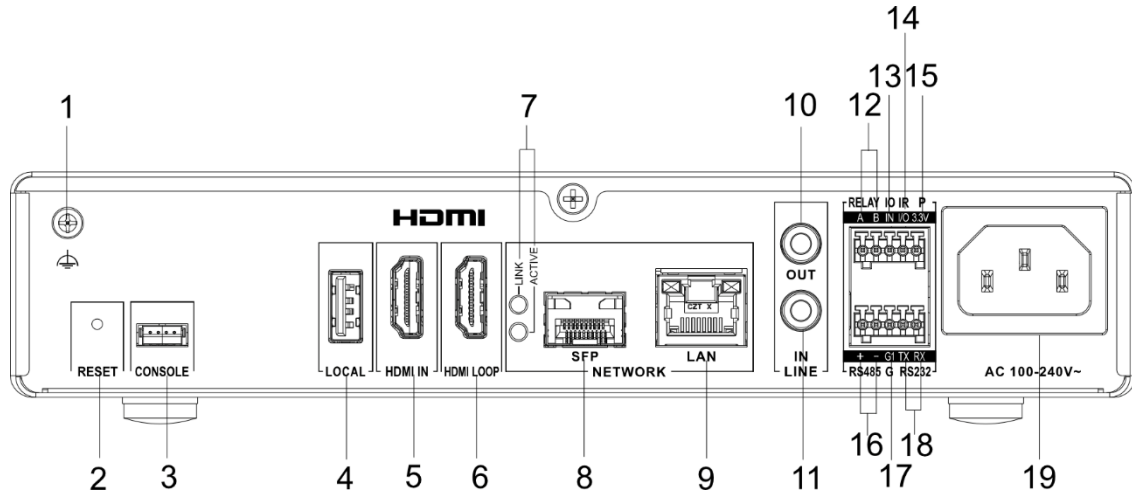

Figure 1-2 Rear Panel of Input Node

No.	Name	Description
1	Grounding point	Connects to the grounding cable.
2	Reset port (RESET)	Hold to restore the factory settings.
3	Console port (CONSOLE)	Connects to the serial port cable for node debugging.
4	USB port (LOCAL)	Connects to the USB flash drive for local node debugging.
5	HDMI input port (HDMI IN)	Connects to the video source via the HDMI port.
6	HDMI loop output port (HDMI LOOP)	Connects to the display via the HDMI port.
7	LINK/ACTIVE LED	Steady green of the LINK LED: the Gigabit SFP port is connected. Flashing yellow of the ACTIVE LED: the Gigabit SFP port is transmitting network data.
8	Gigabit SFP port	Connects to the transceiver module or SFP cable.
9	Gigabit LAN port	Connects to the network cable. PoE is supported.
10	Audio output port (LINE OUT)	Connects to the audio playback device with the amplifier.
11	Audio input port (LINE IN)	Connects to the active audio (such as active microphone).

No.	Name	Description
12	RELAY A/B port	Install the Phoenix contact and then use this port for remote startup/shutdown.
13	Alarm input port (IO IN)	Install the Phoenix contact and then connect this port to a switch sensor.
14	IR input/output port (IR I/O)	Install the Phoenix contact and then connect this port to an IR device.
15	Power socket (P 3.3V)	Install the Phoenix contact and then use this port to provide 3.3 V power supply for a device such as an infrared device.
16	RS-485 port	Install the Phoenix contact and then connect this port to an RS-485 port of a central control device.
17	Grounding port (G1)	Install the Phoenix contact and then connect this port to the grounding cable of a central control device.
18	RS-232 port	Install the Phoenix contact and then connect this port to an RS-232 port of a central control device.
19	Power socket (AC 100-240V)	Connects to the power cord.

Output Node

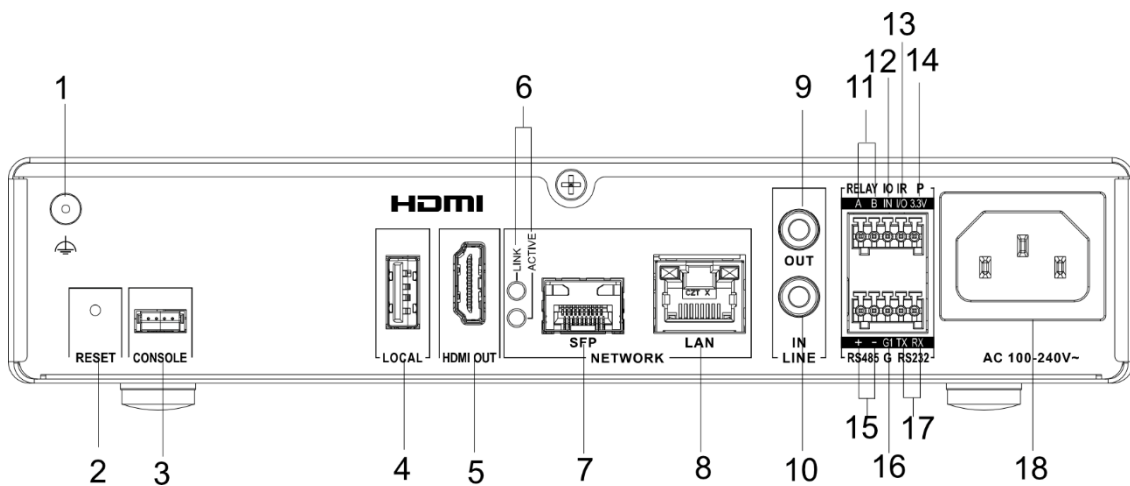

Figure 1-3 Rear Panel of Output Node

No.	Name	Description
1	Grounding point	Connects to the grounding cable.
2	Reset port (RESET)	Hold to restore the factory settings.

No.	Name	Description
3	Console port (CONSOLE)	Connects to the serial port cable for node debugging.
4	USB port (LOCAL)	Connects to the USB device for local node debugging (such as USB flash drive). Connects to the mouse and keyboard.
5	HDMI output port (HDMI OUT)	Connects to the display via the HDMI port.
6	LINK/ACTIVE LED	Steady green of the LINK LED: the Gigabit SFP port is connected. Flashing yellow of the ACTIVE LED: the Gigabit SFP port is transmitting network data.
7	Gigabit SFP port	Connects to the transceiver module or SFP cable.
8	Gigabit LAN port	Connects to the network cable. PoE is supported.
9	Audio output port (LINE OUT)	Connects to the audio playback device with the amplifier.
10	Audio input port (LINE IN)	Connects to the active audio (such as active microphone).
11	RELAY A/B port	Install the Phoenix contact and then use this port for remote startup/shutdown.
12	Alarm input port (IO IN)	Install the Phoenix contact and then connect this port to a switch sensor.
13	IR input/output port (IR I/O)	Install the Phoenix contact and then connect this port to an IR device.
14	Power socket (P 3.3V)	Install the Phoenix contact and then use this port to provide 3.3 V power supply for a device such as an infrared device.
15	RS-485 port	Install the Phoenix contact and then connect this port to an RS-485 port of a central control device.
16	Grounding port (G1)	Install the Phoenix contact and then connect this port to the grounding cable of a central control device.
17	RS-232 port	Install the Phoenix contact and then connect this port to an RS-232 port of a central control device.
18	Power socket (AC 100-240V)	Connects to the power cord.

Chapter 2 Installation

2.1 Installation Process

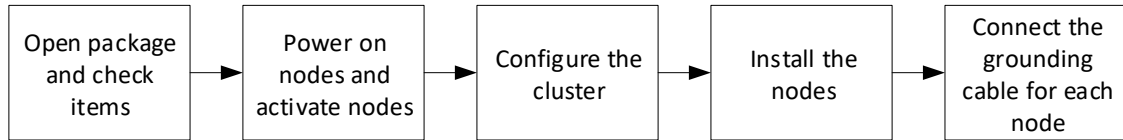

Figure 2-1 First-Time Device Installation Process

2.2 Open Package and Check Items

Open the package of each node to verify that all items in the package are intact according to the packing list.

Table 2-1 Input Node Packing List

Item	Quantity	Item	Quantity
Input node	1	Regulatory compliance and safety information manual	1
AC power cord	1	Connecting brackets	1 pair
Mounting brackets	1 pair		

Table 2-2 Output Node Packing List

Item	Quantity	Item	Quantity
Output node	1	Regulatory compliance and safety information manual	1
AC power cord	1	Connecting brackets	1 pair
Mounting brackets	1 pair		

2.3 Safety Precautions

In order to avoid personal and property injury, please read the safety precautions in this section carefully before installation. The following safety recommendations do not cover all possible

dangerous situations.

Electricity Safety

- During the installation, wiring, disassembly, and maintenance of the device, please disconnect the power supply and do not operate with electricity (except for the operation of the hot plug).
- In the installation and use of the device, make sure to follow the local electrical safety regulations.
- In case of abnormal phenomena such as smoke or odor occur during the use of the device, please cut off the power immediately, unplug the power cord from the socket, and contact the after-sales service center in time.

Anti-Static Measures

The equipment is a precision electronic device. In order to avoid static electricity from damaging the components, in addition to anti-static measures in the equipment room, you must wear anti-static gloves or anti-static wrists during the installation process.

Grounding Requirements

In order to ensure personal safety and device safety, the device must be grounded.

Power Supply Requirements

The device supports 100 VAC to 240 VAC@50/60 Hz power supply. To ensure the stable operation of the device, it is recommended to install UPS for power supply.

Anti-Interference Requirements

- The on-site power supply system must have effective measures to prevent grid interference.
- Do not use the working ground together with the grounding device or lightning protection grounding device of power equipment, and keep the two as far away as possible.
- Keep away from high-power radio transmitters, radar transmitters, and high-frequency and high-current equipment.
- When necessary, electromagnetic shielding can be used for anti-interference.

Environmental Requirements

The device is a system-level monitoring equipment, which is generally placed in the central equipment room of the monitoring system at all levels. The selection of the installation site should comply with the relevant standards of the equipment room construction in the country and region of use.

The device is a standard rack-mounted equipment. Please pay attention to the following information during installation and use:

- Ensure that the temperature in the rack is from 0 °C to 45 °C.
- Ensure that the humidity in the equipment room is between 10% RH and 90% RH.
- Ensure that the rack is strong enough to support the weight of the device and its accessories. During the installation, avoid the risk caused by uneven mechanical load.
- Ensure that there is enough installation space for the video and audio cables. The bending radius of a cable should not be less than 5 times the cable outer diameter.
- To ensure good ventilation, install the device at the position above the ground of at least 4 cm.
- Do not block the air vents and outlets of the device. Keep the air vents and outlets at least 4 cm away from the chassis surface.

2.4 Power On and Activate Nodes

2.4.1 Connect the Power Cords

The power supply should be 100 VAC to 240 VAC@50/60 Hz. After the power cables are connected, the input nodes, output nodes, and switches are powered on.

Step 1 Use a power cord to connect the power socket of an input node to the power supply in the equipment room.

Step 2 Use a power cord to connect the power socket of an output node to the power supply in the equipment room.

Step 3 Use a power cord to connect the power socket of a switch to the power supply in the equipment room.

Step 4 Repeat the above steps to supply power to multiple input nodes, output nodes, and switches.

2.4.2 Batch Activate Nodes

Use SADP Client

Step 1 Connect all nodes and the computer to the same LAN.

Step 2 Visit <https://www.hikvision.com/en/support/tools/hitools/clea8b3e4ea7da90a9/> to download the SADP client from the Hikvision website and install the SADP client on the computer.

Step 3 Open the SADP client.

Step 4 Select the nodes that are not activated, enter the activation password and confirm it, and click **Activate**.

If no nodes can be found, you can restart the SADP client.

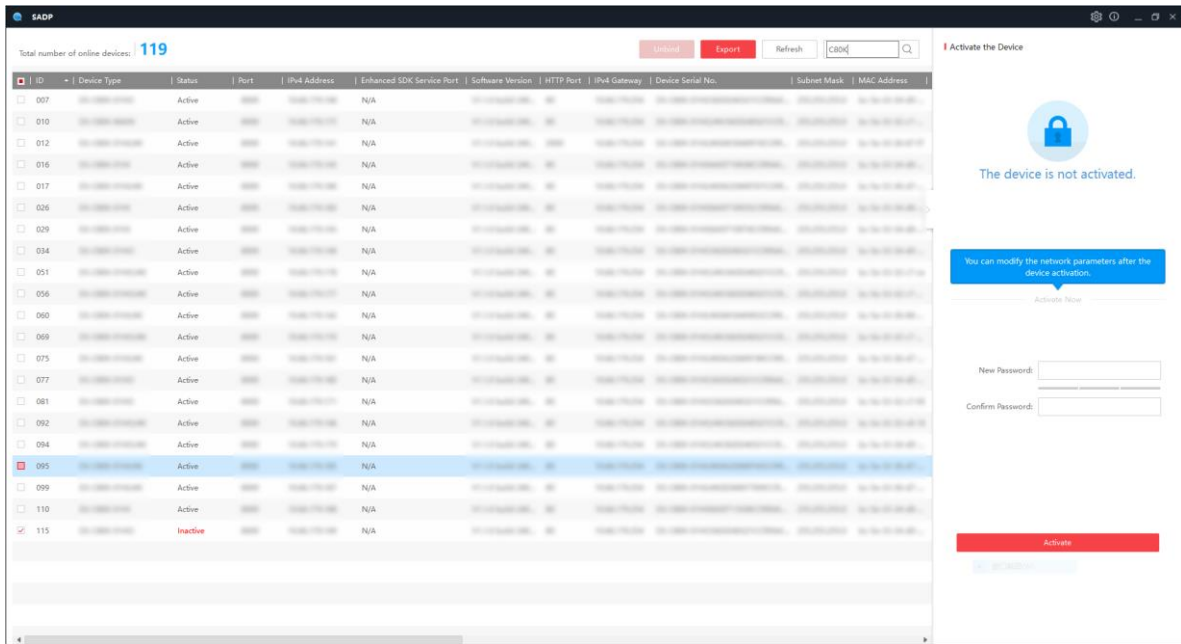

Figure 2-2 Batch Activate Nodes

Use HiTools Delivery

Step 1 Connect all nodes and the computer to the same LAN.

Step 2 Visit <https://www.hikvision.com/en/support/tools/hitools/cl7f0143d2c781a3e3/> to download the HiTools Delivery client from the Hikvision website and install the HiTools Delivery client on the computer.

Step 3 Open the HiTools Delivery client.

Step 4 Select the nodes that are not activated, enter the activation password and confirm it, and click **Activation**.

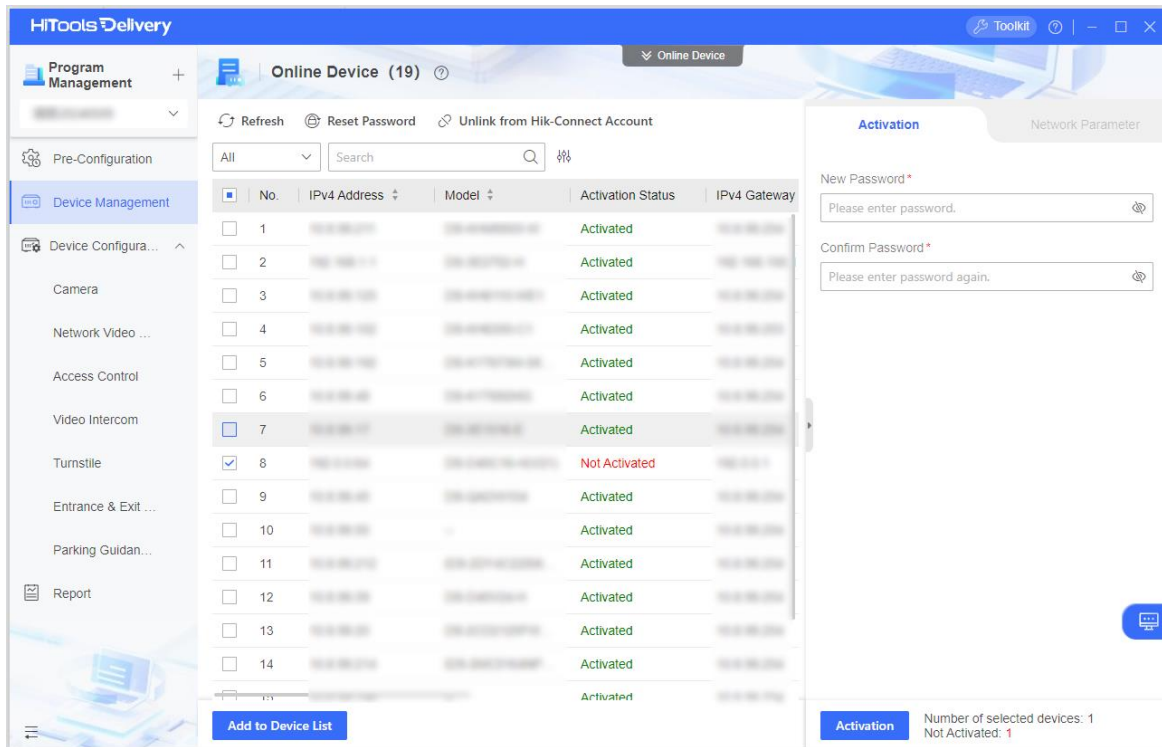

Figure 2-3 Batch Activate Nodes

2.5 Configure the Cluster

To use multiple input nodes and output nodes to form a distributed video wall controller, you need to configure the cluster.

2.5.1 Check the Streaming Mode

Step 1 Enter the IP address of an output node in the web browser of the computer.

Step 2 Enter the user name and the set activation password, and click **Log In**.

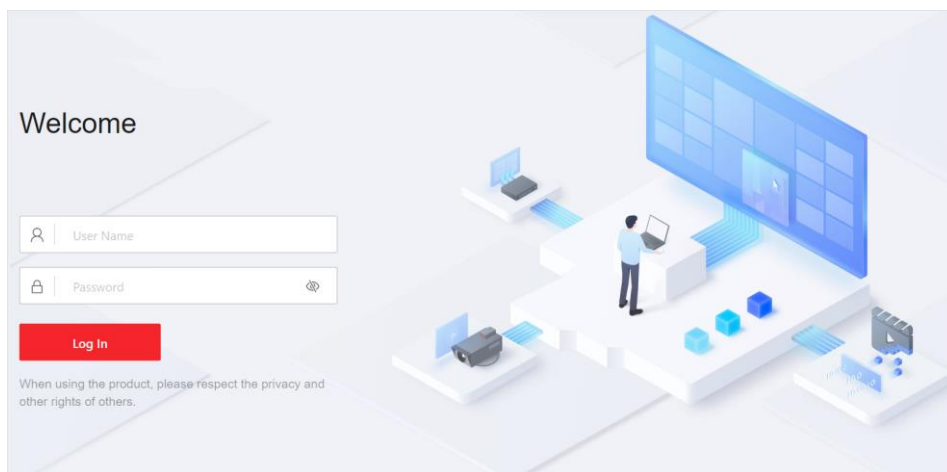

Figure 2-4 Login Page

Step 3 Go to **Configuration** → **Device Settings**, and enable **Set as Main Control**.

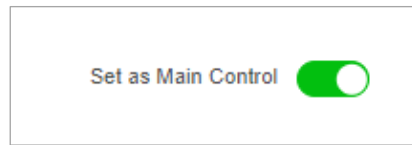

Figure 2-5 Set as Main Control

Step 4 Go to **Configuration** → **Other Settings** → **Streaming Mode**, make sure the unicast window streaming mode is selected.

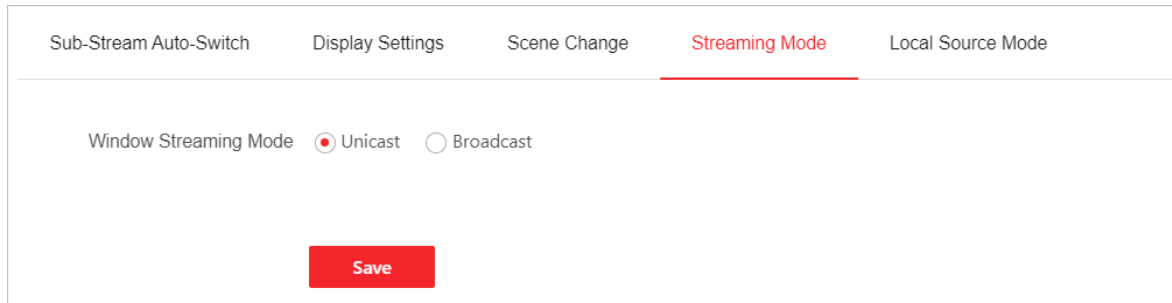

Figure 2-6 Select Unicast Streaming Mode

2.5.2 Select a Switch Type

Two types of switches are available. Each switch supports a maximum of 24 nodes. Select a switch type as required. For more information about the switch, see the switch data sheet.

Table 2-3 Switch Type and Port Parameters

Type	Ports
Switch 1	24 × 10/100/1000BASE-T ports (including 8 × combo interfaces) + 4 × 1G/10G BASE-X SFP+ ports
Switch 2	24 × SFP ports (including 8 × combo interfaces) + 4 × 1G/10G BASE-X SFP+ ports

2.5.3 Connect Nodes to Switches

Connect Nodes to Switches 1

Step 1 Use one CAT 6 or above Ethernet cable to connect the LAN port of an input node (1) to a network port of the switch (3).

Step 2 Use one CAT 6 or above Ethernet cable to connect the LAN port of an output node (2) to a network port of the switch (3).

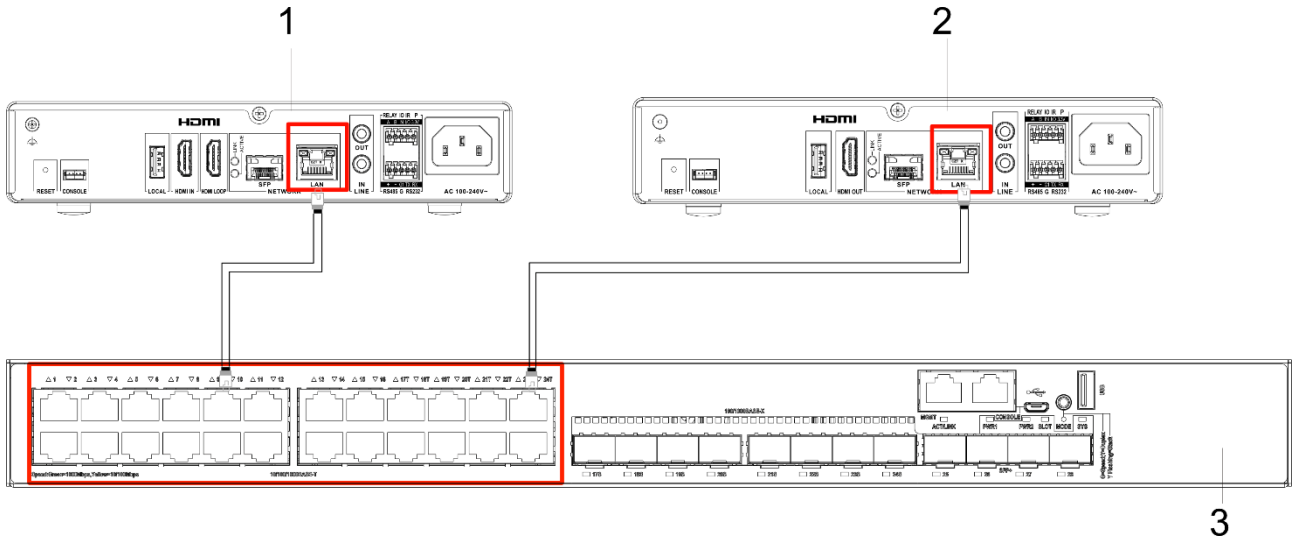

Figure 2-7 Connect Nodes to Switch 1

Step 3 Use one SFP+ cable to connect two switches.

Step 4 Repeat the above steps to connect multiple input nodes and output nodes to each switch, and then connect multiple switches.

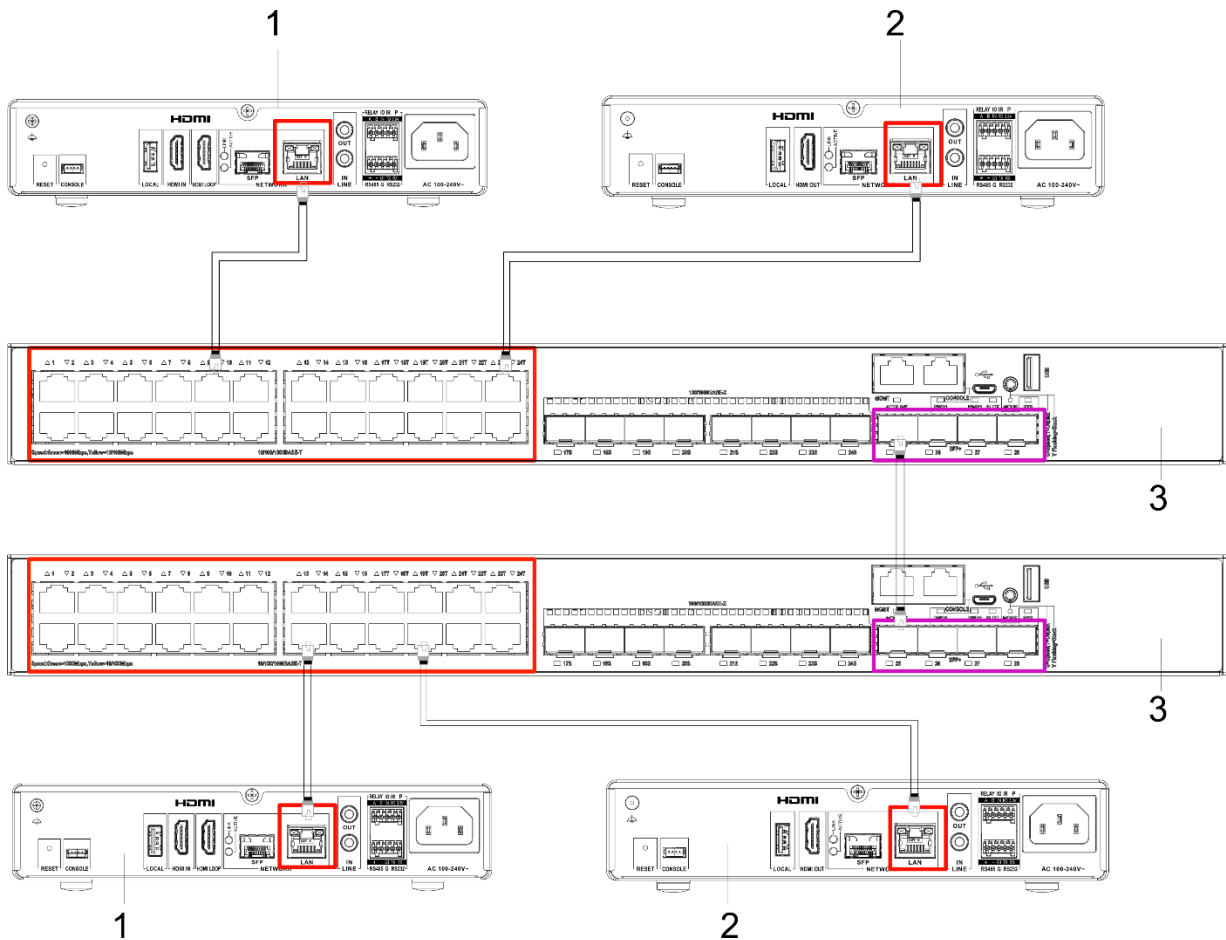

Figure 2-8 Connect Nodes to Switches 1

Connect Nodes to Switches 2

Step 1 Use one SFP cable to connect the SFP port of an input node (1) to an SFP port of the switch (3).

Step 2 Use one SFP cable to connect the SFP port of an output node (2) to an SFP port of the switch (3).

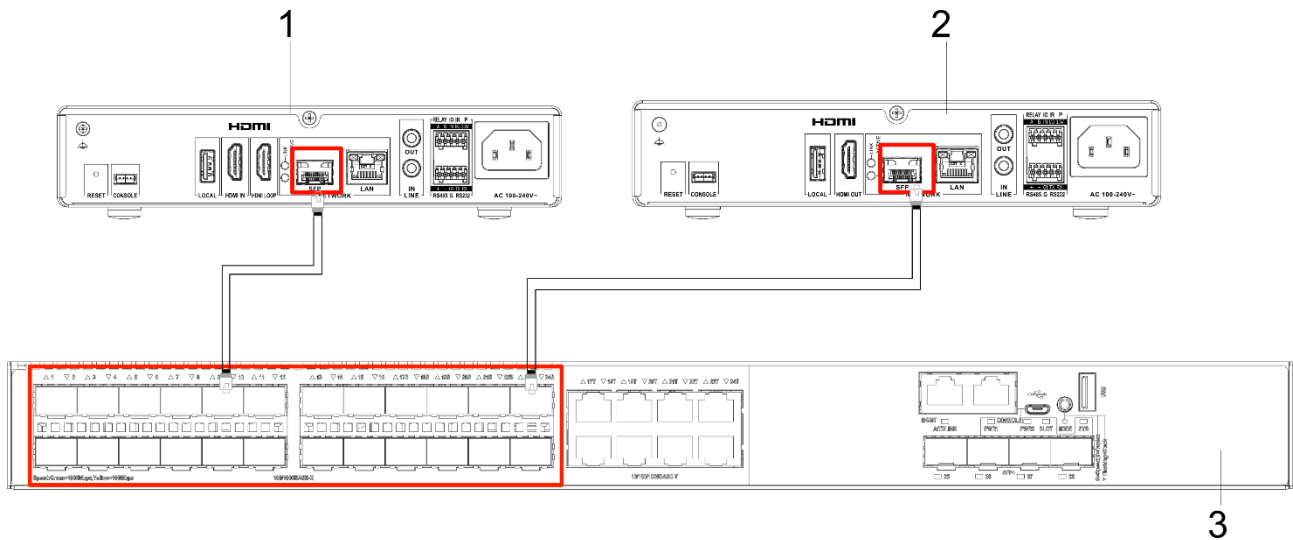

Figure 2-9 Connect Nodes to Switch 2

Step 3 Use one SFP+ cable to connect two switches.

Step 4 Repeat the above steps to connect multiple input nodes and output nodes to each switch, and then connect multiple switches.

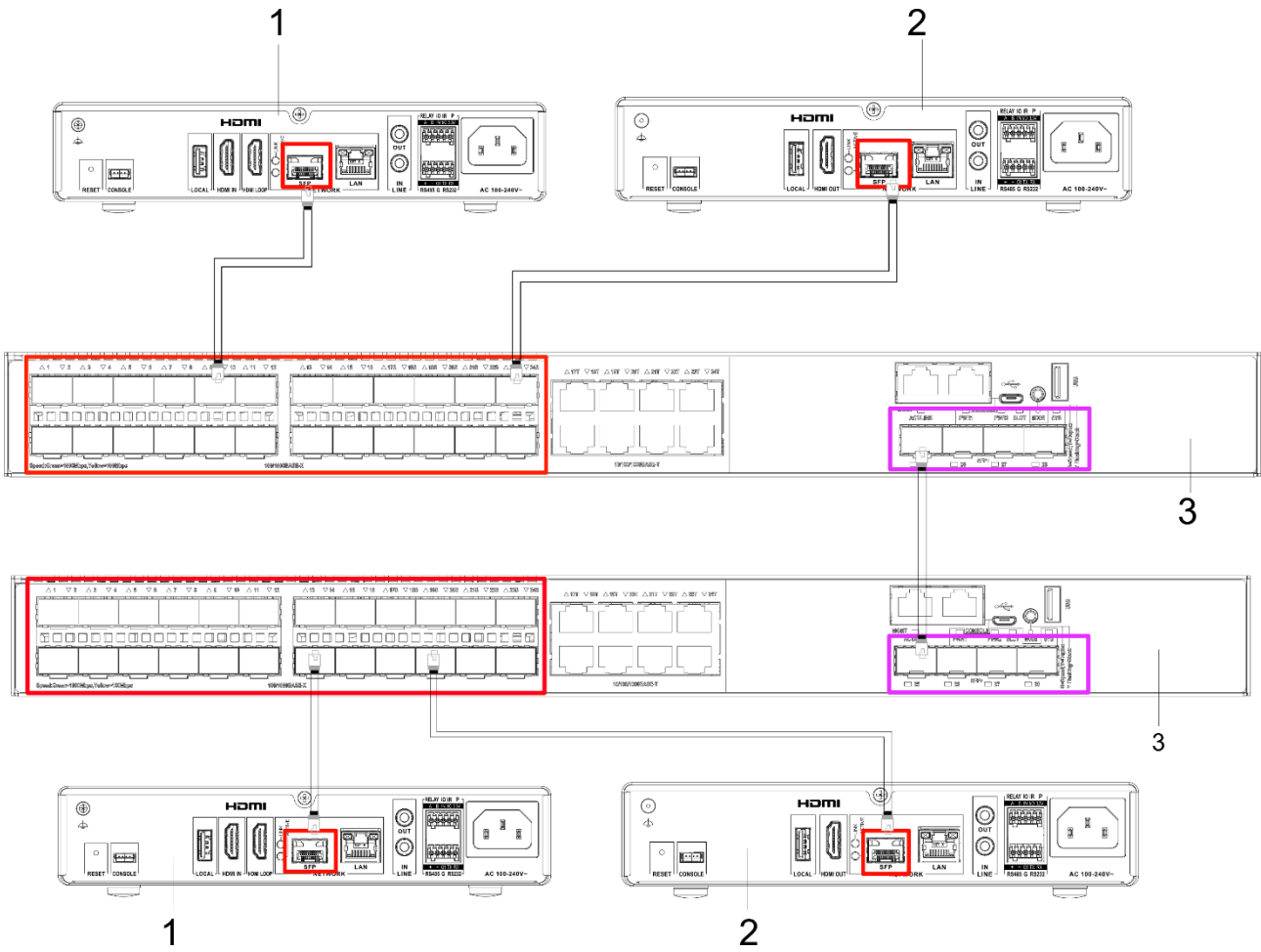

Figure 2-10 Connect Nodes to Switches 2

2.5.4 Connect the Computer to a Switch

Connect the Computer to a Switch 1

Step 1 Use a USB to DB-9 serial adapter cable to connect the USB port of the computer.

Step 2 Use a DB-9 to RJ-45 cable (1) to connect the console port of a switch (2).

Step 3 Connect the USB to DB-9 serial adapter cable and the DB-9 to RJ-45 cable.

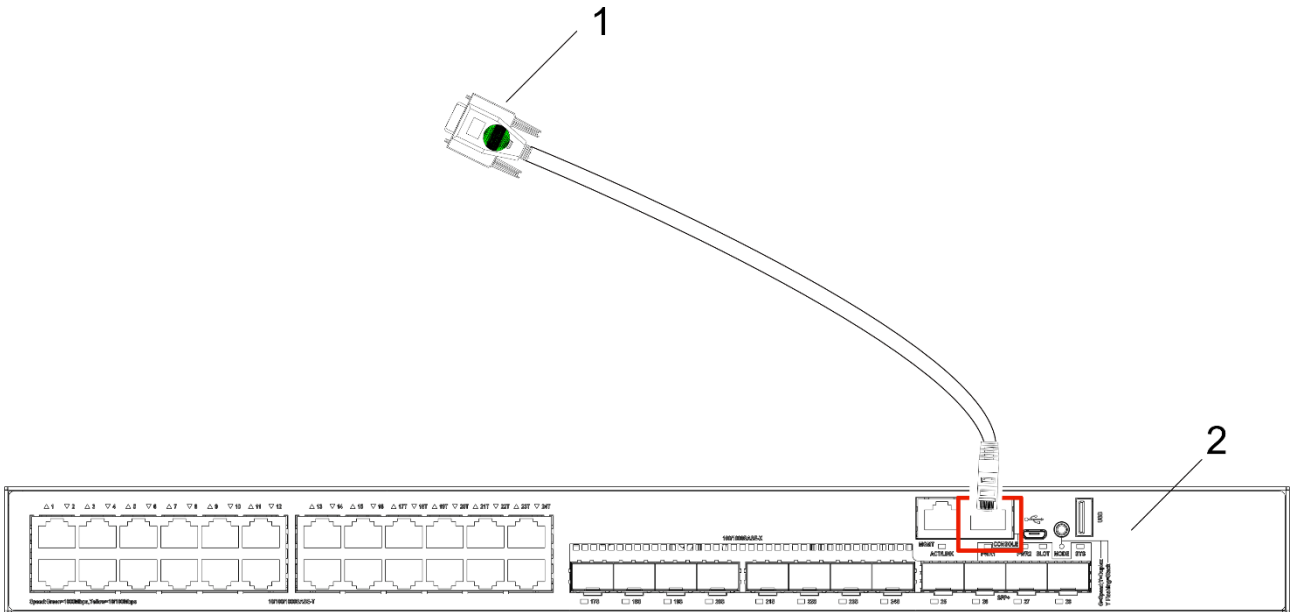

Figure 2-11 Connect a Computer to a Switch 1

Connect the Computer to a Switch 2

Step 1 Use a USB to DB-9 serial adapter cable to connect the USB port of the computer.

Step 2 Use a DB-9 to RJ-45 cable (1) to connect the console port of a switch (2).

Step 3 Connect the USB to DB-9 serial adapter cable and the DB-9 to RJ-45 cable.

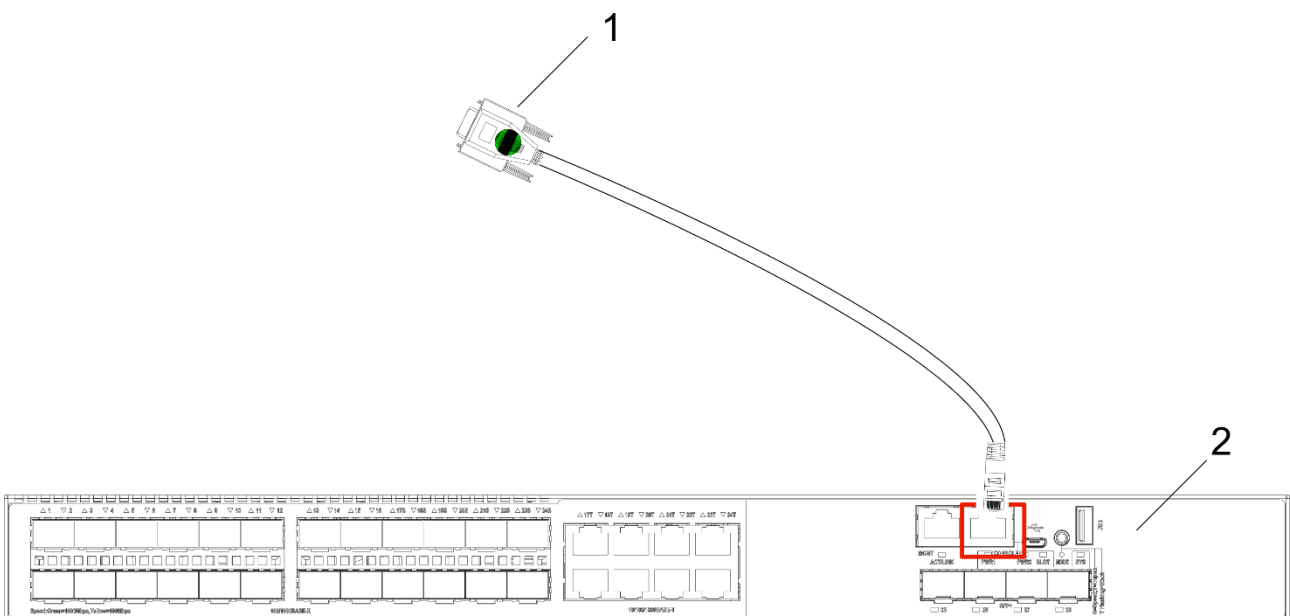

Figure 2-12 Connect a Computer to a Switch 2

2.5.5 Configure the Command Lines

Regardless the switch type, the command lines configuration methods are the same. The following uses switch 1 as an example.

Using One Switch

Step 1 Connect the nodes to one switch and connect the computer to the switch.

Step 2 Open a terminal tool on the computer. The following uses the MobaXterm tool as an example.

1. Click **Session**.
2. On the pop-up session settings window, click **Serial**.
3. Select a serial port and set the speed to 9600, and click **OK**.

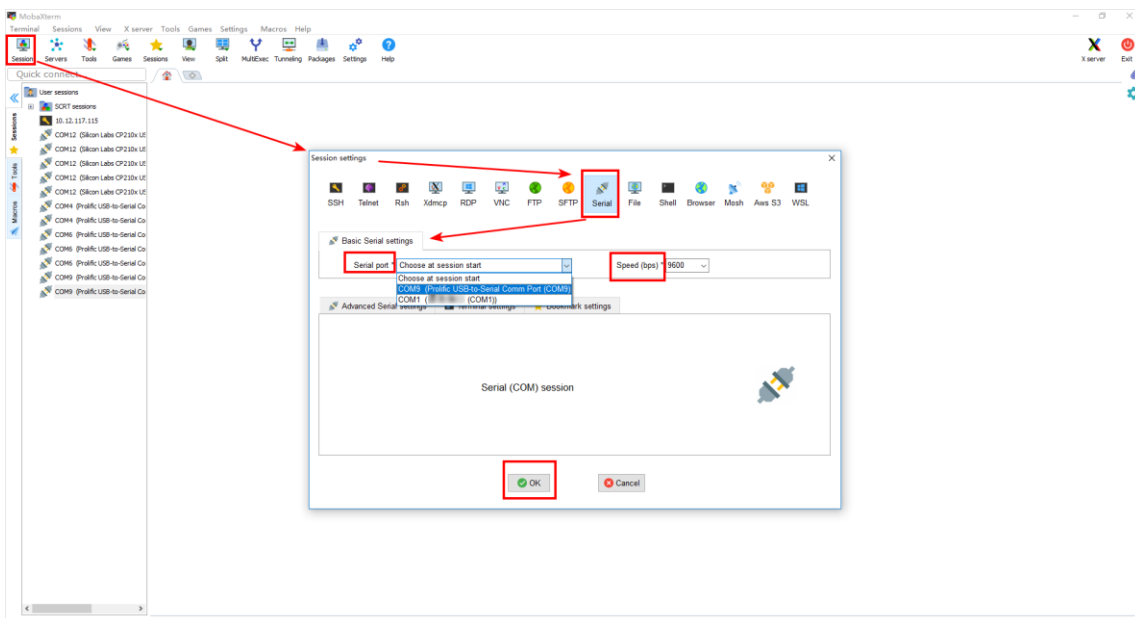

Figure 2-13 MobaXterm Settings

Step 3 Press **Enter** to check the connection between the switch and computer. If you see **HIK**, the computer is connected to the switch.



Figure 2-14 Check the Connection Between Computer and Switch

Step 4 Enter **sys** to enter system view.

Step 5 Enter **undo stp global enable** to disable STP protocol.

Step 6 Enter **display stp** to check the STP protocol status. If you see **Disabled**, the STP protocol is disabled.

```
<HIK>sys
System View: return to User View with Ctrl+Z.
[HIK]undo stp global enable
[HIK]display stp
Protocol status      : Disabled
Protocol Std.       : IEEE 802.1s
Version             : 3
Bridge-Prio.        : 32768
MAC address         : 
Max age(s)          : 20
Forward delay(s)    : 15
Hello time(s)       : 2
Max hops            : 20
TC Snooping         : Disabled
[HIK]
```

Figure 2-15 Disable STP Protocol

Step 7 Enter **save** to save the configuration.

```
[HIK]save
The current configuration will be written to the device. Are you sure? [Y/N]:y
Please input the file name(*.cfg)[flash:/startup.cfg]
(To leave the existing filename unchanged, press the enter key):
flash:/startup.cfg exists, overwrite? [Y/N]:y
Validating file. Please wait...
Saved the current configuration to mainboard device successfully.
[HIK]
```

Figure 2-16 Save Configuration

Use Multiple Switches

Step 1 Connect the nodes to multiple switches, connect multiple switches, and connect the computer to a switch.

Step 2 Open a terminal tool on the computer. The following uses the MobaXterm tool as an example.

1. Click **Session**.
2. On the pop-up session settings window, click **Serial**.
3. Select a serial port and set the speed to 9600, and click **OK**.

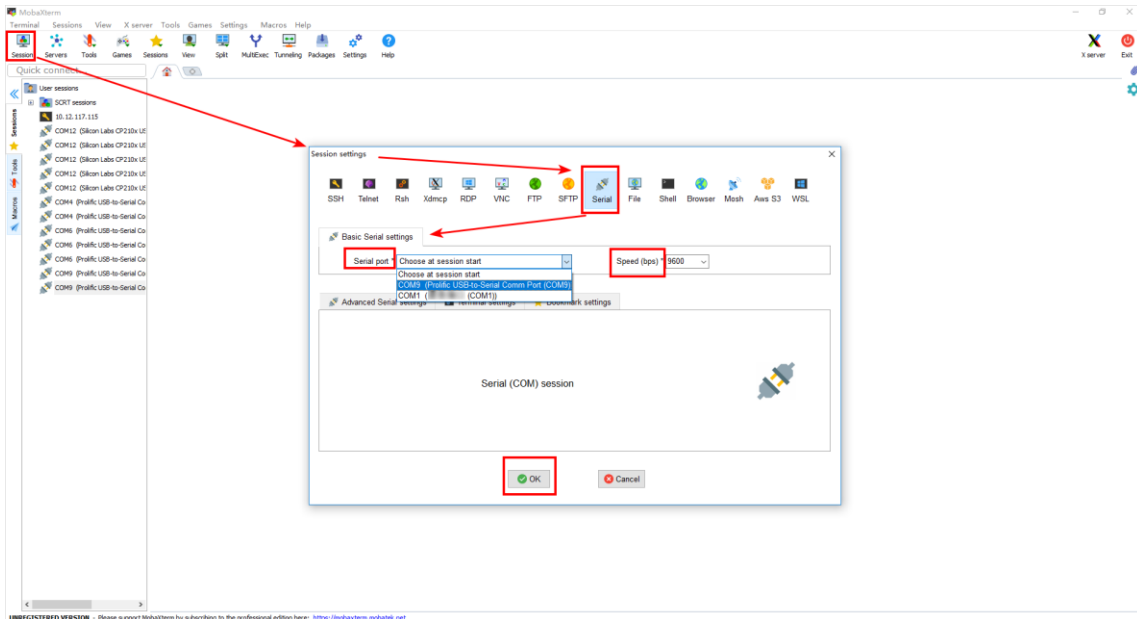

Figure 2-17 MobaXterm Settings

Step 3 Press **Enter** to check whether HIK displays on the computer. If you see HIK, the computer is connected to the switch.



Figure 2-18 Check the Connection Between Computer and Switch

Step 4 Enter **undo stp global enable** on the computer to disable STP protocol.

Step 5 Enter **display stp** to check the STP protocol status. If you see **Disabled**, the STP protocol is disabled.

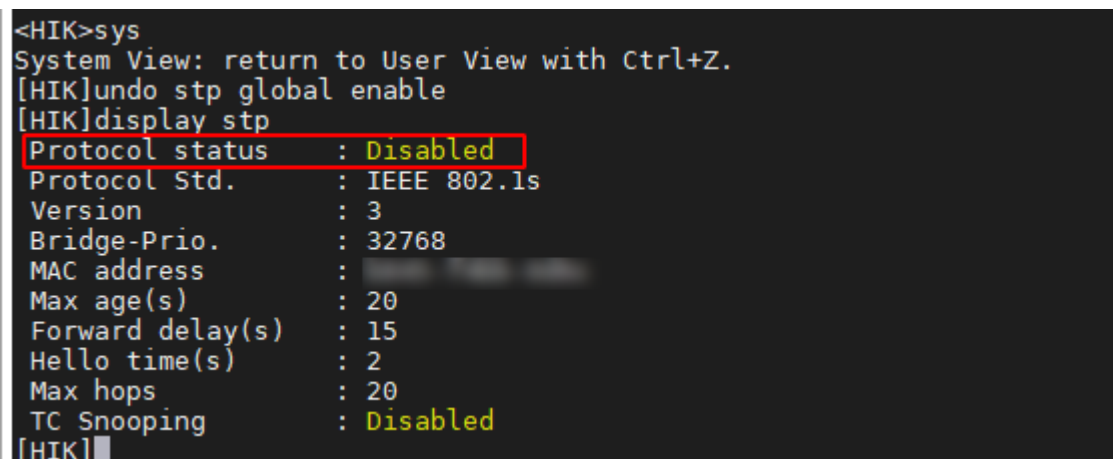

Figure 2-19 Disable STP Protocol

Step 6 Use two SFP+ cables to connect two switches when each switch is connected with more than 10 UHD input/output nodes or 20 HD input/output nodes.

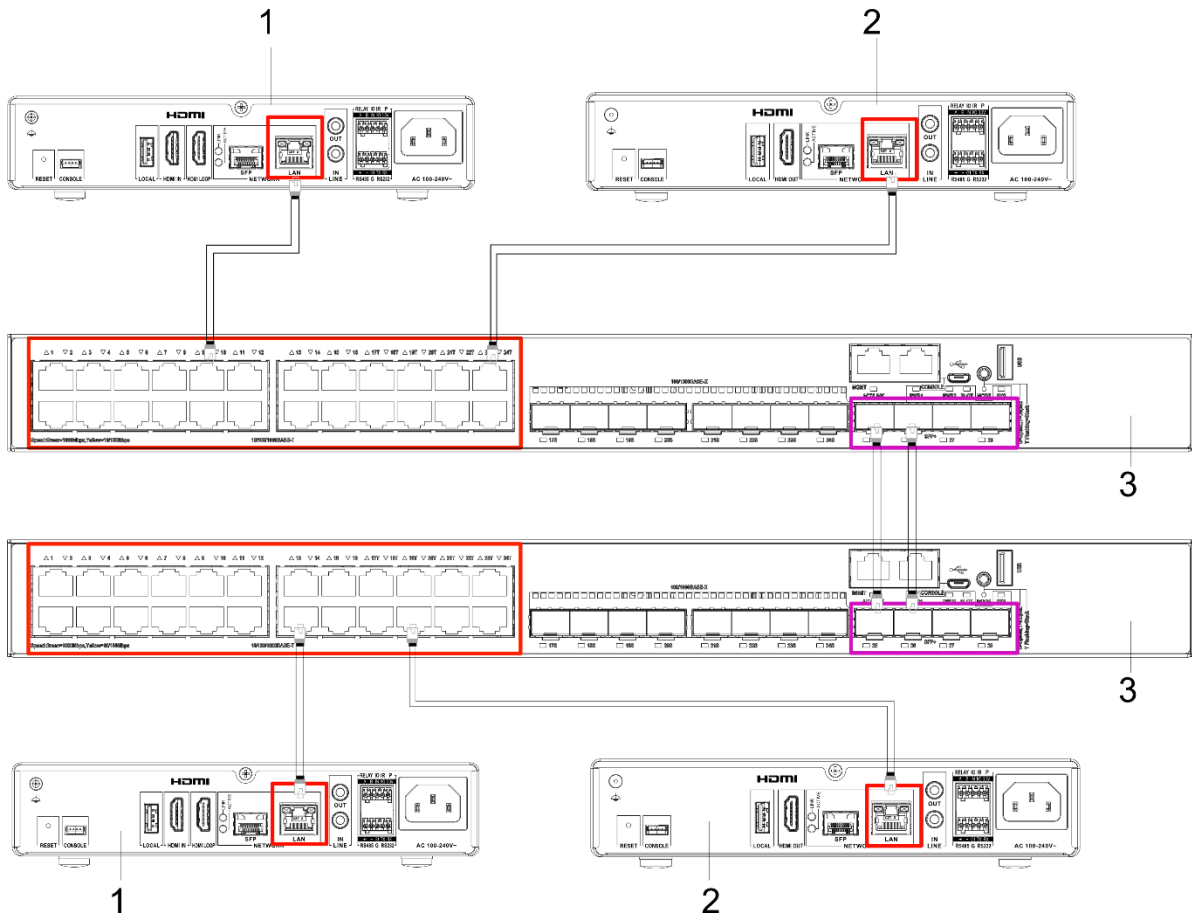

Figure 2-20 Use Two SFP+ Cables

Step 7 Configure the port aggregation:

1. Enter **interface bridge-aggregation 1** to create the port aggregation group 1.
2. Enter **port link-type access** to set the port type as access.
3. Enter **link-aggregation mode dynamic** to use the dynamic port aggregation mode.
4. Enter **interface Ten-GigabitEthernet 1/0/25** and then **port link-aggregation group 1** to add the SFP+ port 25 to the port aggregation group 1.
5. Enter **interface Ten-GigabitEthernet 1/0/26** and then **port link-aggregation group 1** to add the SFP+ port 25 to the port aggregation group 1.
6. Enter **display link-aggregation verbose** to check the port aggregation status.

```
[HIK]
[HIK]interface bridge-aggregation 1
[HIK-Bridge-Aggregation1]port link-type access
Configuring Ten-GigabitEthernet1/0/25 done.
Configuring Ten-GigabitEthernet1/0/26 done.
[HIK-Bridge-Aggregation1]link-aggregation mode dynamic
[HIK-Bridge-Aggregation1]quit
[HIK]interface Ten-GigabitEthernet 1/0/25
[HIK-Ten-GigabitEthernet1/0/25]port link-aggregation group 1
[HIK-Ten-GigabitEthernet1/0/25]quit
[HIK]interface Ten-GigabitEthernet 1/0/26
[HIK-Ten-GigabitEthernet1/0/26]port link-aggregation group 1
[HIK-Ten-GigabitEthernet1/0/26]quit
[HIK]display link-aggregation verbose
Loadsharing Type: Shar -- Loadsharing, NonS -- Non-Loadsharing
Port Status: S -- Selected, U -- Unselected, I -- Individual
Port: A -- Auto port, M -- Management port, R -- Reference port
Flags: A -- LACP_Activity, B -- LACP_Timeout, C -- Aggregation,
       D -- Synchronization, E -- Collecting, F -- Distributing,
       G -- Defaulted, H -- Expired

Aggregate Interface: Bridge-Aggregation1
Creation Mode: Manual
Aggregation Mode: Dynamic
Loadsharing Type: Shar
Management VLANs: None
System ID: 0x8000, b845-f4bb-0d6c
Local:

| Port      | Status | Priority | Index | Oper-Key | Flag  |
|-----------|--------|----------|-------|----------|-------|
| XGE1/0/25 | U      | 32768    | 1     | 1        | {ACG} |
| XGE1/0/26 | U      | 32768    | 2     | 1        | {ACG} |

Remote:

| Actor     | Priority | Index | Oper-Key | SystemID               | Flag |
|-----------|----------|-------|----------|------------------------|------|
| XGE1/0/25 | 32768    | 0     | 0        | 0x8000, 0000-0000-0000 | {EF} |
| XGE1/0/26 | 32768    | 0     | 0        | 0x8000, 0000-0000-0000 | {EF} |

[HIK]
```

Figure 2-21 Configure Port Aggregation

Step 8 Enter **save** to save the configuration.

```
[HIK]save
The current configuration will be written to the device. Are you sure? [Y/N]:y
Please input the file name(*.cfg)[flash:/startup.cfg]
(To leave the existing filename unchanged, press the enter key):
flash:/startup.cfg exists, overwrite? [Y/N]:y
Validating file. Please wait...
Saved the current configuration to mainboard device successfully.
[HIK]
```

Figure 2-22 Save Configuration

2.6 Install the Nodes

The input nodes should be connected to the computer, and the output nodes should be connected to the displays. Please select the installation location and method according to the position of the computer and displays.

2.6.1 Rack Installation

Note

- Prepare the rack and screws by yourself.
- There are two types of connecting brackets. Please select the installation method according to the type of the actual connecting bracket.

Using Connecting Brackets 1

Step 1 Use two KM3 × 6 countersunk screws to install one mounting bracket to the left side of the node front panel. Use the same method to install the other mounting bracket to the right side of the node front panel.

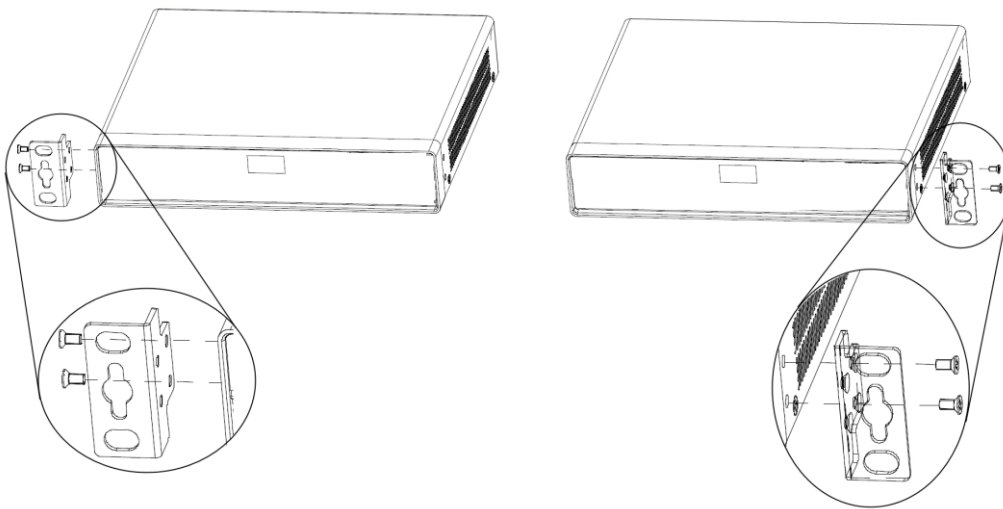

Figure 2-23 Install the Mounting Brackets

Step 2 Use two TWM3 × 6 pan-head screws to install two connecting brackets to the inner sides of two nodes with the FRONT surface facing forward.

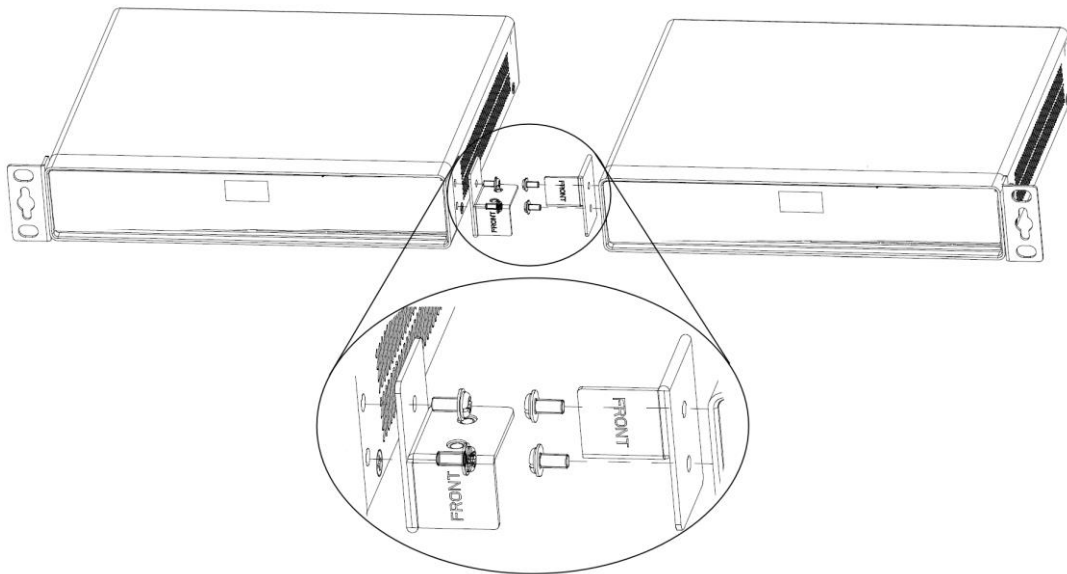

Figure 2-24 Install the Connecting Brackets 1

Step 3 Use two TWM3 × 6 pan-head screws to secure the connecting brackets.

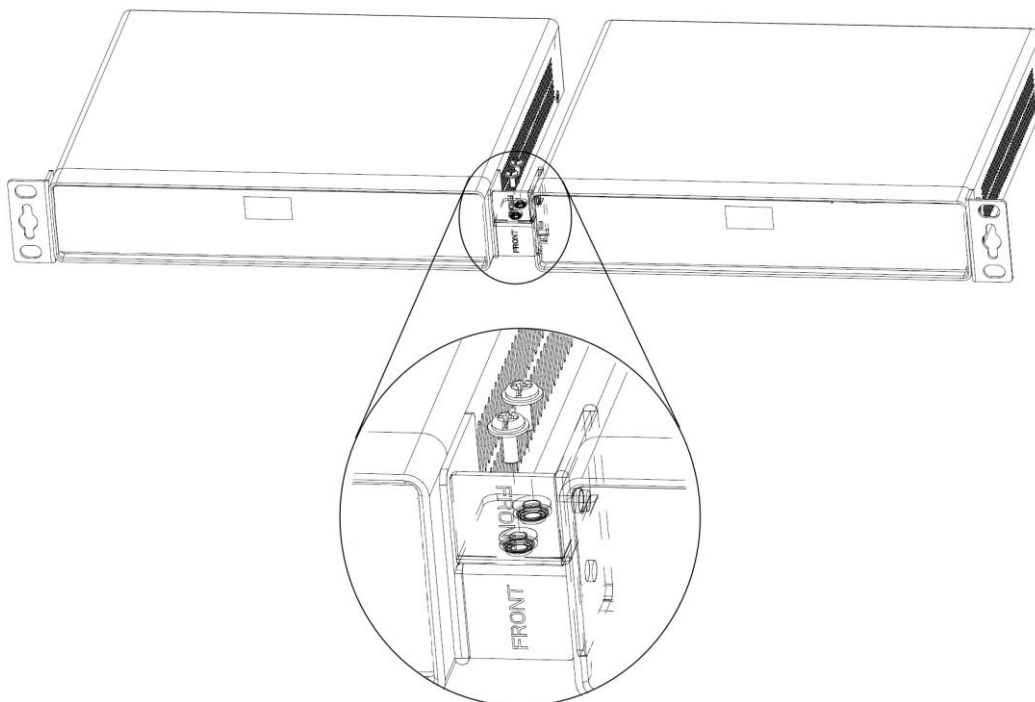

Figure 2-25 Secure the Connecting Brackets 1

Step 4 Prepare the clip nuts and M5 screws or M6 screws to secure two nodes to the rack post.

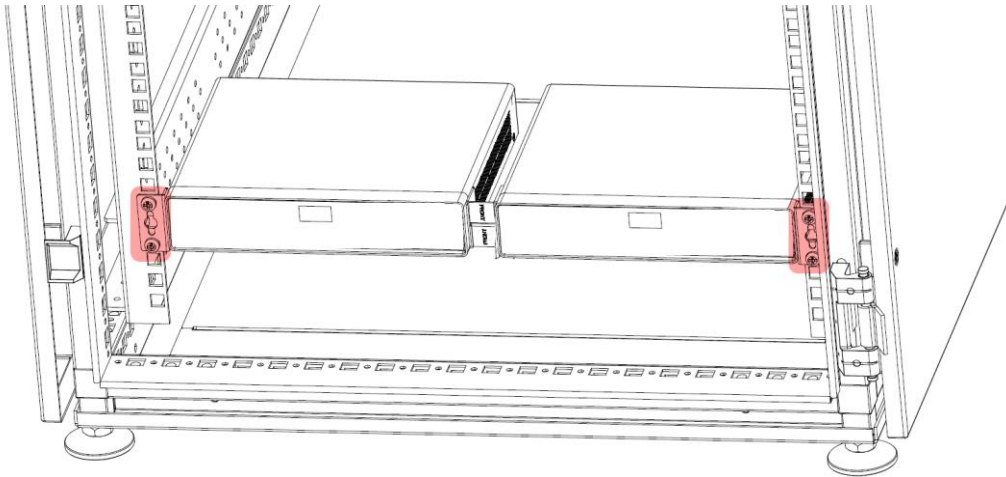

Figure 2-26 Secure Nodes to the Rack

Note

If you install multiple layers of nodes in the rack, keep at least one rack post hole between each layer of nodes.

Using Connecting Brackets 2

Step 1 Use two KM3 × 6 countersunk screws to install one mounting bracket to the left side of the node front panel. Use the same method to install the other mounting bracket to the right side of the node front panel.

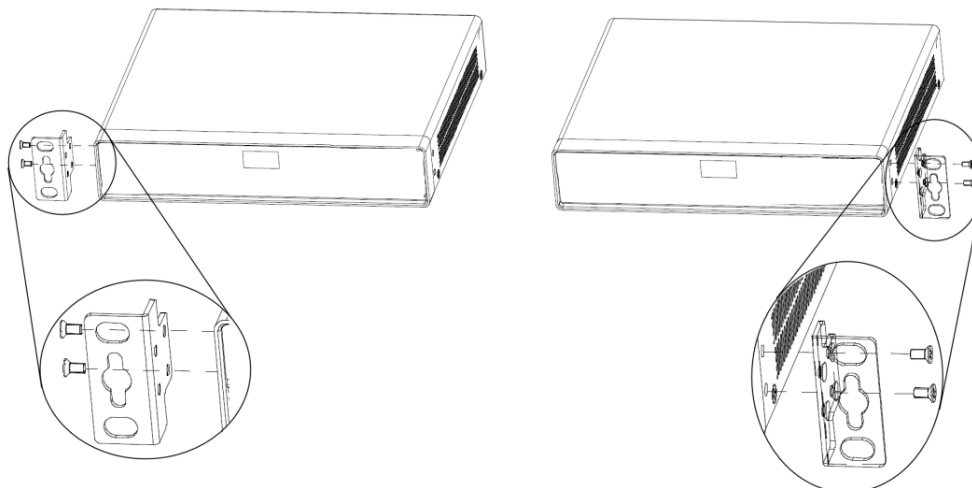

Figure 2-27 Install the Mounting Brackets

Step 2 Use two KM3 × 6 countersunk screws to install two connecting brackets to the inner sides of two nodes with the FRONT surface facing forward and arrow facing upward.

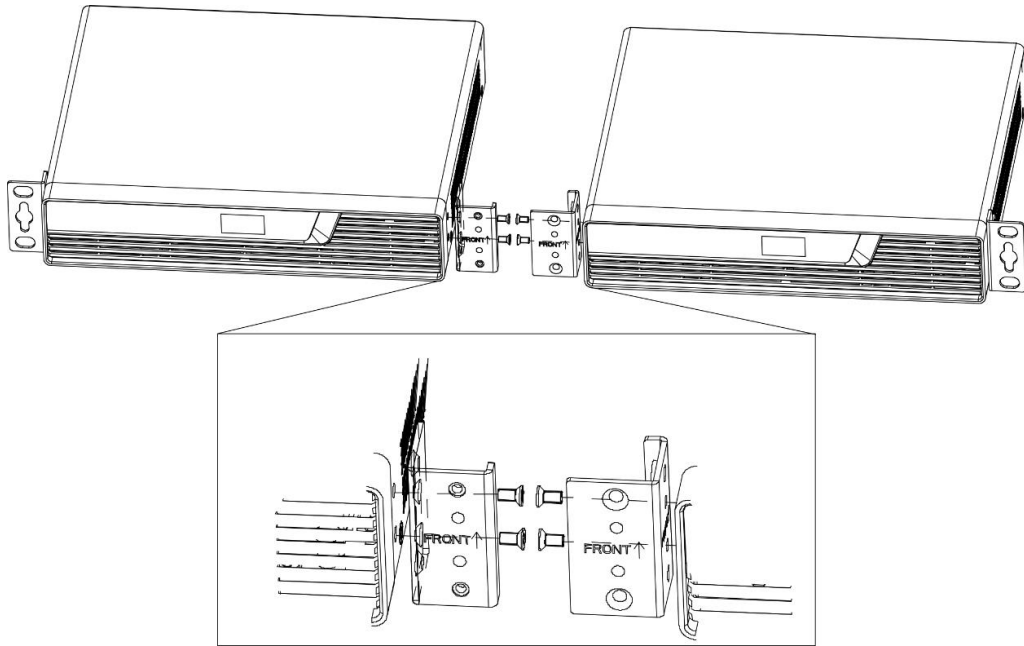

Figure 2-28 Install the Connecting Brackets 2

Step 3 Use two KM3 × 6 countersunk screws to secure the connecting brackets.

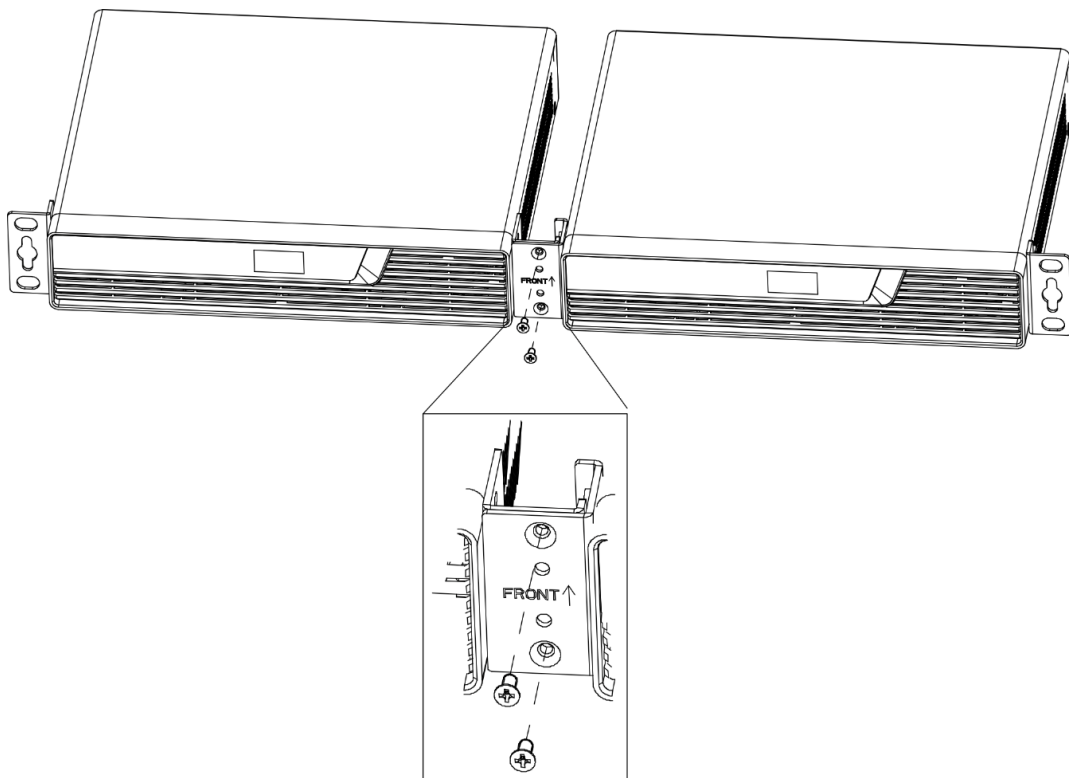

Figure 2-29 Secure the Connecting Brackets 2

Step 4 Prepare the clip nuts and M5 screws or M6 screws to secure two nodes to the rack post.

Note

If you install multiple layers of nodes in the rack, keep at least one rack post hole between each layer of nodes.

2.6.2 Magnetic Installation

Note

- Please purchase magnetic pads from Hikvision.
- Please purchase screws by yourself.

Step 1 Remove the four silicone pads on the bottom of the node.

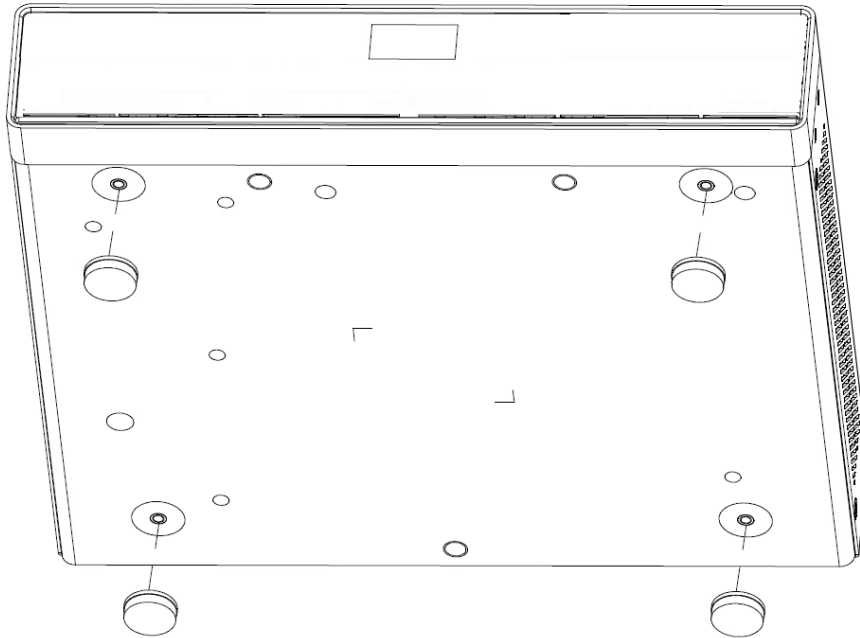

Figure 2-30 Remove Silicone Pads

Step 2 Use four KM3 × 8 countersunk screws to fix the four magnetic pads to the bottom of the node.

Note

Use the appropriate locking torque to make the outer ring silicone of magnetic pad is slightly higher than the magnet.

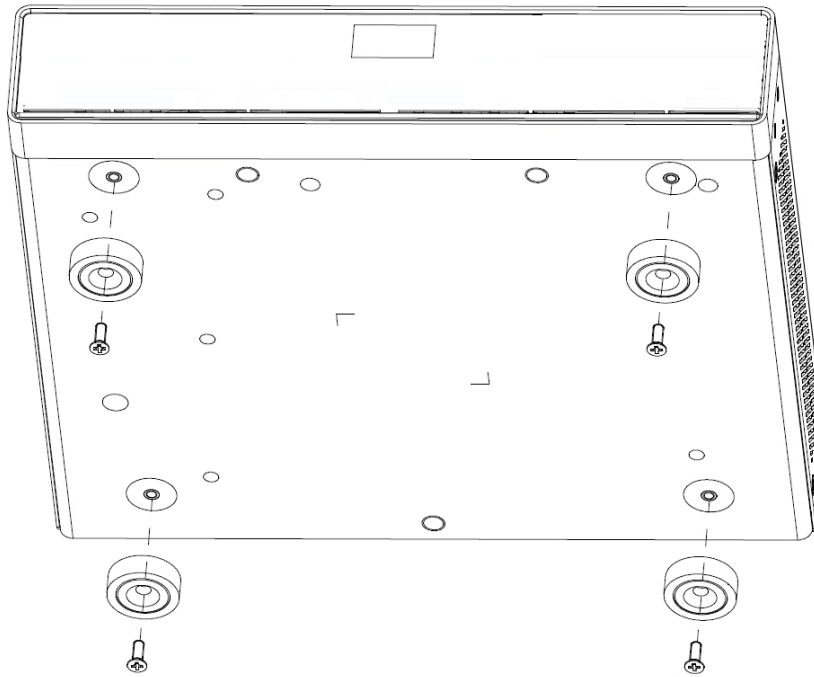

Figure 2-31 Fix Magnetic Pads

Step 3 Attach the node to the back of the iron display or other iron materials.

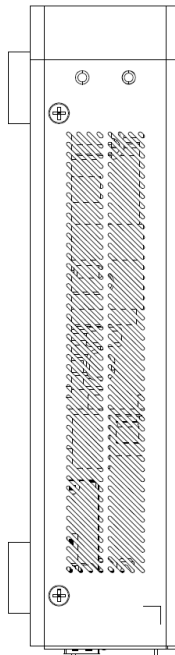

Figure 2-32 Magnetic Installation

2.7 Connect the Grounding Cable for Each Node

Connecting the grounding cable can release the excessive voltage and current induced by lightning shock. Please select the most suitable connection mode to protect the grounding cable according to the installation environment.

With Grounding Row

Step 1 Connect one end of the grounding cable (2) to the grounding terminal of the grounding row (3) in the equipment room.

Step 2 Connect the other end of the grounding cable to the grounding terminal of a node (1) and tighten the screw.

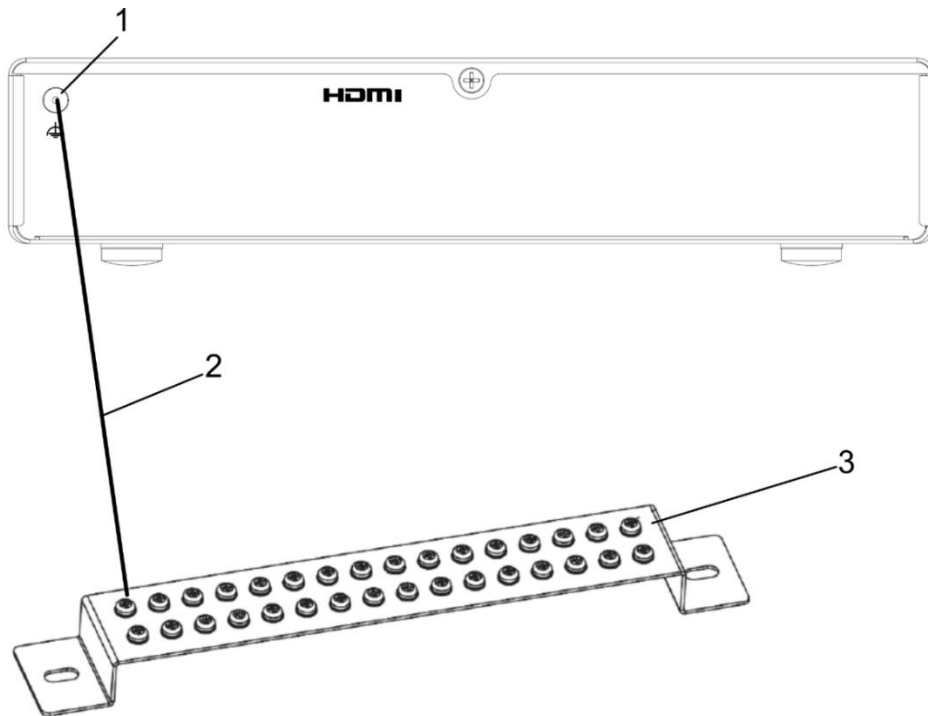

Figure 2-33 Connect the Grounding Cable to the Grounding Row

Without Grounding Row

Step 1 Drive an angle steel (4) or steel pipe into the ground (3) of at least 0.5 m.

Step 2 Weld one end of the grounding cable (2) to the angle steel or steel pipe and treat the welding points with corrosion protection (electroplate or coating).

Step 3 Connect the other end of the grounding cable to the grounding terminal of a node (1).

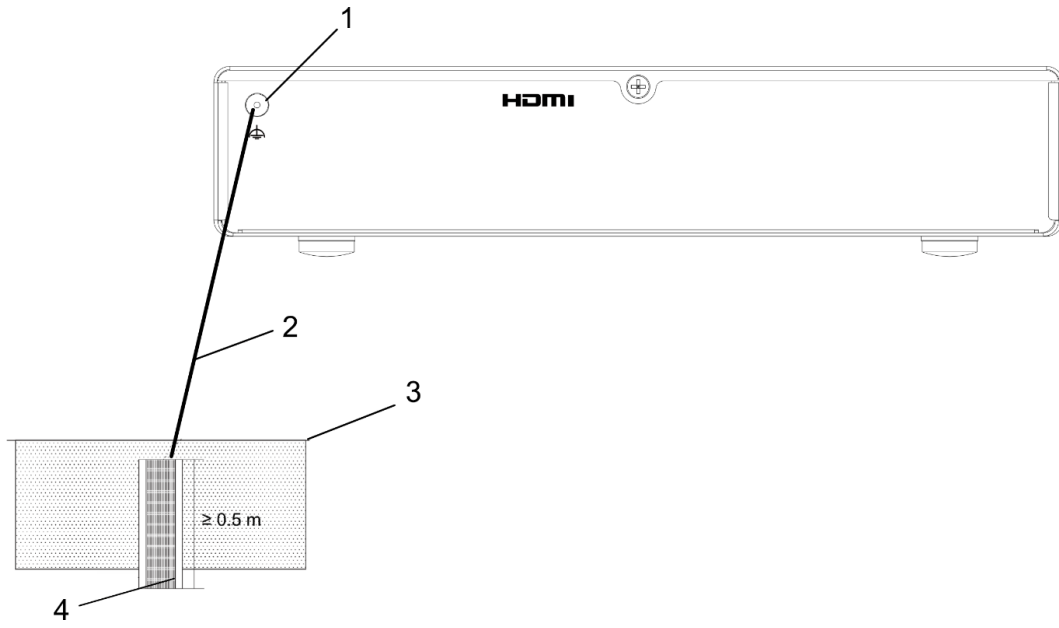

Figure 2-34 Connect the Grounding Cable to the Ground

Chapter 3 Get More Information

Scan the QR code below to view the [user manual](#).



The following operations require network data traffic and are recommended to be performed in a Wi-Fi environment.



Figure 3-1 User Manual



See Far, Go Further