

DS-1772ZJ-ED2-AC

Wall Mount

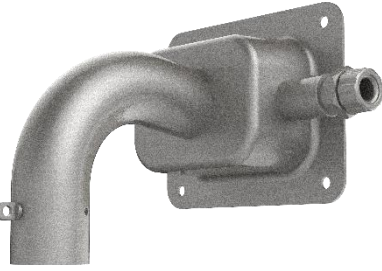

Features

- 316L Stainless steel material with anti-corrosion surface spray treatment
- Quick to install
- Applies to speed dome

Dimension

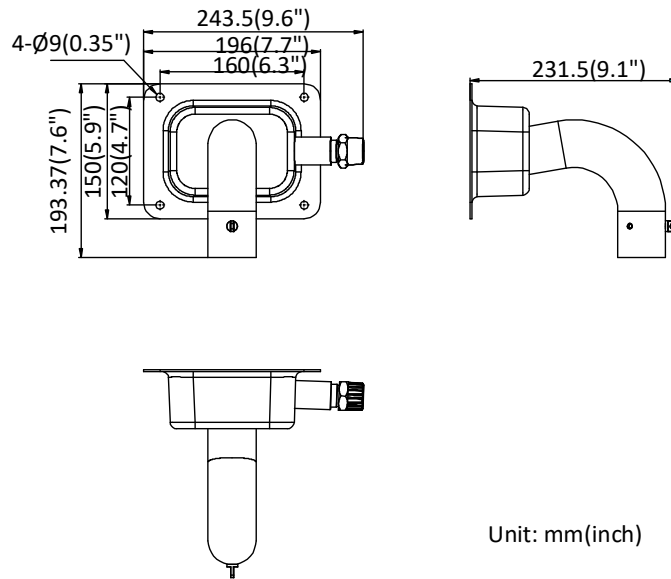

Available Model

DS-1772ZJ-ED2-AC

Parameter

Model	DS-1772ZJ-ED2-AC
Parameters	Wall Mount
Material	Stainless steel 316L
Appearance	Silver moon grey
Dimension	243.5 mm × 231.5 mm × 193.4 mm (9.6" × 9.1" × 7.6")
Weight	Approx. 2 kg (4.41 lb.)

Note

The maximum load capacity of the bracket is 15 kg (33.1 lb.).