

DS-1690ZJ-X

Wall Mount



Feature

- SUS304 Stainless steel
- Applicable to explosion-proof speed dome (PTZ camera)

Dimension

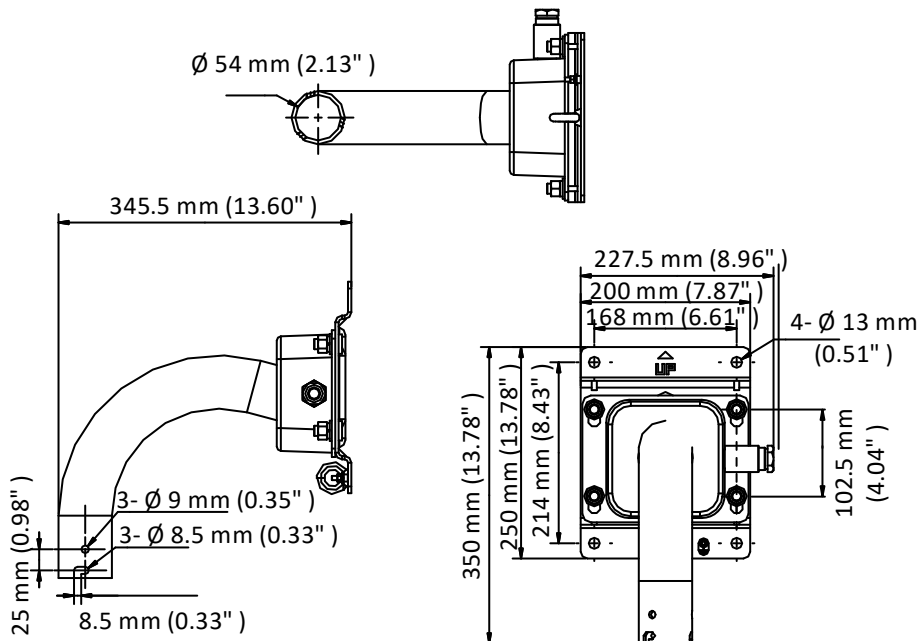

Available Model

DS-1690ZJ-X

Parameter

Model	DS-1690ZJ-X
Parameters	Wall Mount
Appearance	Natural Stainless Steel Color
Material	SUS304
Dimension	350 mm × 227.5 mm × 345.5 mm (13.78" × 8.96" × 13.60")
Weight	7 kg (15.43 lb.)

Note

- The mount should be installed on the flat wall.
- The waterproof rubber is necessary for the outdoor application.
- The wall must be capable of supporting at least 8 times as much as the total weight of the camera, and the mount.
- The mount's maximum load capacity is 30 kg (66 lb.).